



TENTS AND EQUIPMENT

INFLATABLE AWNINGS



Grande AIR Tour, Grande AIR Stay, Rally AIR Tour, Rally AIR Tour DA, Rally AIR Stay, Leggera AIR, Leggera AIR DA, Club AIR Tour

EN	Awning tent Installation and Operating Manual.....	13	SV	Förtält Monterings- och bruksanvisning.....	70
DE	Vorzelt Montage- und Bedienungsanleitung.....	20	NO	Markisetelt Monterings- og bruksanvisning.....	77
FR	Tente auvent Instructions de montage et de service.....	28	FI	Etuteltta Asennus- ja käyttöohje.....	84
ES	Tienda toldo Instrucciones de montaje y de uso.....	35	PL	Namiot przedsiolkowy Instrukcja montażu i obsługi.....	91
PT	Tenda de toldo Instruções de montagem e manual de instruções.....	42	SK	Markízový stan Návod na montáž a uvedenie do prevádzky.....	99
IT	Tenda veranda Istruzioni di montaggio e d'uso.....	49	CS	Přístřeškový stan Návod k montáži a obsluze.....	106
NL	Voortent Montagehandleiding en gebruiksaanwijzing.....	56	HU	Előtető sátor Szerelési és használati útmutató.....	113
DA	Fortelt Monterings- og betjeningsvejledning.....	63			

More accessories

	Canopy*	Extension**
Leggera AIR 220	9120000289	–
Leggera AIR 260	9120000288	–
Grande AIR Tour EXT L/H S	–	9120002345
Grande AIR Tour EXT R/H S	–	9120002346
Grande AIR Stay EXT L/H S	–	9120002404
Grande AIR Stay EXT R/H S	–	9120002405

***Canopy:** German: Vordach; French: Toit solaire autonome; Spanish: Carpa; Portuguese: Pavilhão; Italian: Tendalino; Dutch: Paviljoentent; Danish: Solafskærmning; Swedish: Baldakin; Norwegian: Baldakin; Finnish: Katos; Polish: Daszek; Slovak: Kryt; Czech: Stříška; Hungarian: Előtető

****Extension:** German: Erweiterung; French: Extension; Spanish: Extensión; Portuguese: Extensão; Italian: Estensione; Dutch: Uitbreiding; Danish: Udvidelse; Swedish: Förlängning; Norwegian: Forlengelse; Finnish: Jatke; Polish: Przedłużenie; Slovak: Rozšírenie; Czech: Přístavba; Hungarian: Hosszabbító

	Mesh front panel*	Roof lining**
Rally AIR 200	9120000197	9120001174
Rally AIR 260	9120000196	9120001175
Rally AIR 330	9120000195	9120001176
Rally AIR 390	9120000194	9120001177
Grande AIR 390	9120000194	9120001184
Rally AIR 260 DA	–	9120001300
Rally AIR 330 DA	–	9120001301
Rally AIR 390 DA	–	9120001302
Club AIR 260	9120000194	9120001180
Club AIR 330	9120000193	9120001181
Club AIR 390	9120000192	9120001182

***Mesh front panel:** German: Fliegengitter Vorderseite; French: Panneau avant en maille; Spanish: Mosquitera frontal; Portuguese: Painel frontal em malha; Italian: Tenda frontale a rete; Dutch: Horgaas-voorpaneel; Danish: Frontpanel i net; Swedish: Frontpanel i mesh; Norwegian: Frontpanelnetting; Finnish: Verkollinen etuseinä; Polish: Moskitiera przednia; Slovak: Sietovaný predný panel; Czech: Přední panel ze síťoviny; Hungarian: Hálós elülső pane

****Roof lining:** German: Dachverkleidung; French: Revêtement de toit; Spanish: Techo interior; Portuguese: Revestimento da cobertura; Italian: Rivestimento del tetto; Dutch: Dakvoering; Danish: Termoloft; Swedish: Takklädsel; Norwegian: Takfóring; Finnish: Kattokangas; Polish: Okładzina sufitu; Slovak: Čalúnenie stropu; Czech: Střešní obložení; Hungarian: Tetőbélés

	Continental carpet*	Footprint**
Rally AIR 200	9120000293	9120000363

	Continental carpet*	Footprint**
Rally AIR 260	9120000294	9120000364
Rally AIR 330	9120000295	9120000365
Rally AIR 390	9120000296	9120000366
Grande AIR 390	9120000298	9120000368
Leggera AIR 220	9120000285	9120000385
Leggera AIR 260	9120000286	9120000386
Leggera AIR 300	9120002441	9120002440
Club AIR 260	–	9120001207
Club AIR 330	–	9120000374
Club AIR 390	–	9120000375

Continental carpet*: German: Teppichboden; French: Tapis continental; Spanish: Alfombra continental; Portuguese: Tapete continental; Italian: Moquette continentale; Dutch: Continentale vloerbedekking; Danish: Kontinentalt tæppe; Swedish: Kontinentalt matta; Norwegian: Kontinentalt teppe; Finnish: Manneralueen matto; Polish: Dywan kontynentalny; Slovak: Kontinentálny koberec; Czech: Kontinentální koberec; Hungarian: Kontinentális szőnyeg

Footprint**: German: Zeltunterlage; French: Tapis de sol; Spanish: Suelo adicional; Portuguese: Tapete de chão; Italian: Telo di fondo; Dutch: Grondzeil; Danish: Underlag; Swedish: Markskydd; Norwegian: Bunnduk; Finnish: Pohjapeite; Polish: Podkład pod namiot; Slovak: Podložka pod stan; Czech: Podlážka; Hungarian: Sátor alátét;



NOTE

For more accessories please visit dometic.com.

German: Weitere Zubehörteile finden Sie unter dometic.com.

French: Pour plus d'accessoires, rendez-vous sur dometic.com.

Spanish: Para ver más accesorios, visite dometic.com.

Portuguese: Para obter mais acessórios, visite dometic.com.

Italian: Per ulteriori accessori, visitare il sito dometic.com.

Dutch: Ga voor meer accessoires naar dometic.com.

Danish: Du kan finde mere tilbehør på dometic.com.

Swedish: Fler tillbehör finns på dometic.com.

Norwegian: Du finner flere tilbehørsartikler på dometic.com.

Finnish: Lisää lisävarusteita on osoitteessa dometic.com.

Polish: Więcej akcesoriów można znaleźć na stronie dometic.com.

Slovak: Ďalšie príslušenstvo nájdete na stránke dometic.com.

Czech: Další příslušenství naleznete na adrese dometic.com.

Hungarian: További tartozékokért látogasson el a dometic.com oldalra.

Technical data

	↔ (mm)	⊥ (mm)	👤 (kg)	≥ (kg)
Grande AIR Tour				
390 S	3900	3000	24.5 / 7.2	18.1
390 M	3900	3000	25.1 / 7.2	18.6
Grande AIR Stay				
390 S	3900	3000	29.3 / 8.9	26.8
260 S	2600	2500	21.3	15.8
Rally AIR Stay				
330 S	3300	2500	22.3	16.9
Rally AIR Tour				
200 S	2000	2500	19	10.3
260 S	2600	2500	24.2	13.1
260 M	2600	2500	24.7	13.7
330 S	3300	2500	26	14.1
330 M	3300	2500	26.5	14.7
390 S	3900	2500	27.6	15.2
390 M	3900	2500	28.1	15.2
260 DA	2600	2500	25.1 / 7.2	15
330 DA	3300	2500	26.5 / 8.2	20.7
390 DA	3900	2500	27.1 / 9.1	24
Leggera AIR				
220 S	2200	2400	8.7	7.4
260 S	2600	2400	12.2	8.4
260 M	2600	2400	12.6	9
330 S	3000	2400	12.96	9.54
260 DA	2600	2400	17.4	13.12
Club AIR Tour				
260 S	2600	2750	27.3	18.3
330 S	3300	2750	30.5	18.5
390 S	3900	2750	32.3	19.4

1

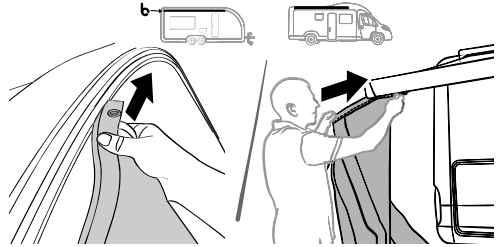
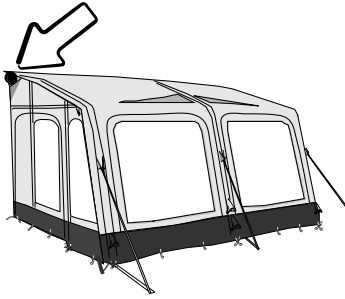

2

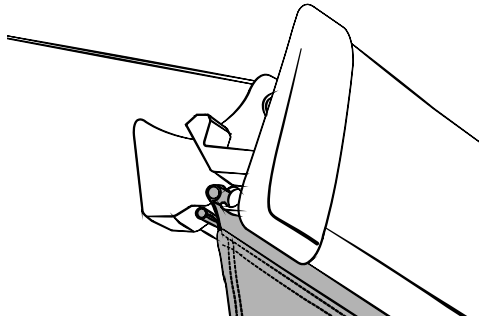
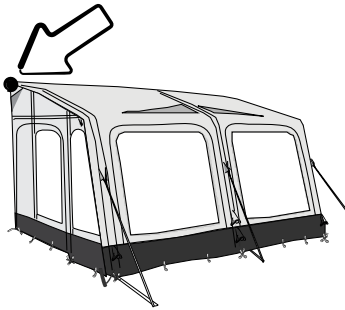

3

Rally AIR Tour DA,
Leggera AIR Tour DA

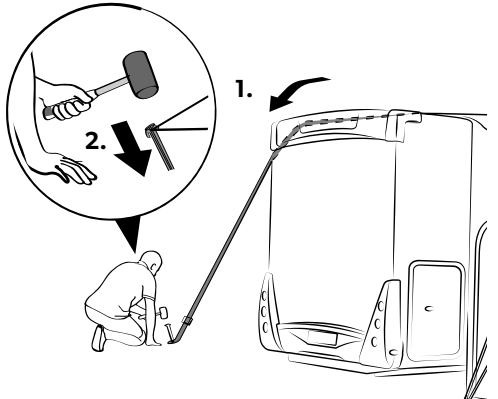
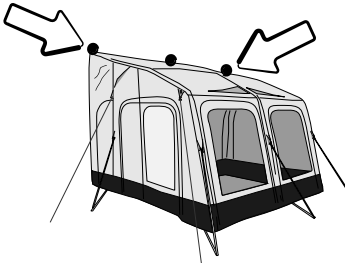

4

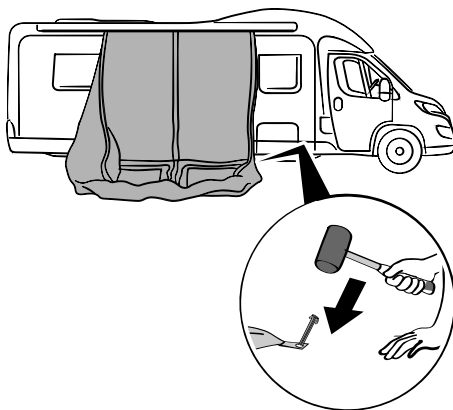
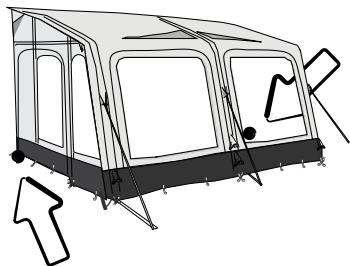

5

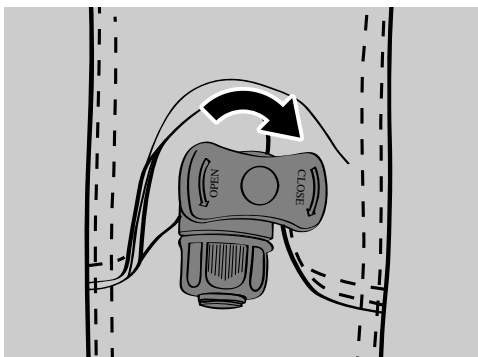
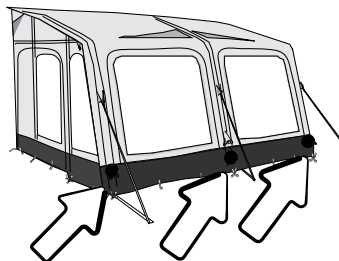

6

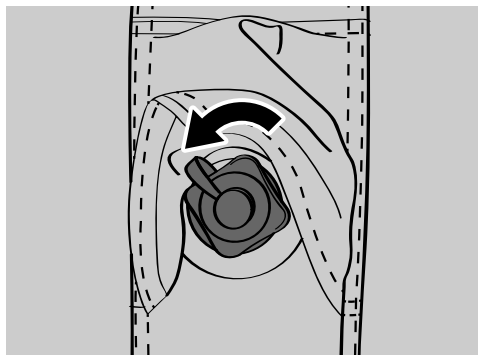
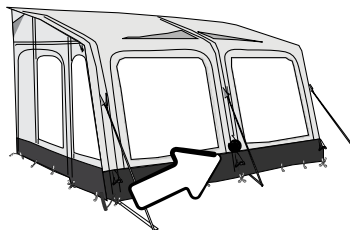

7

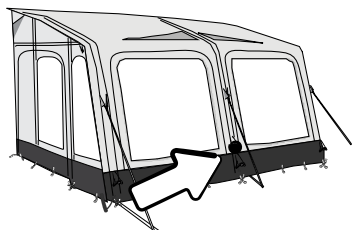

9 PSI / 0.62 bar

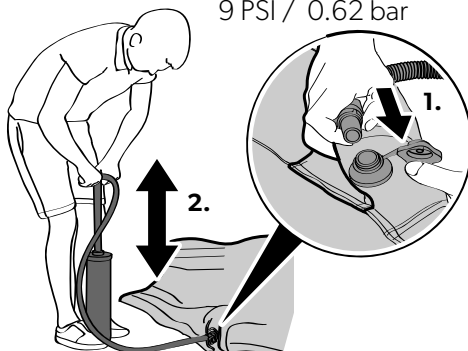

8

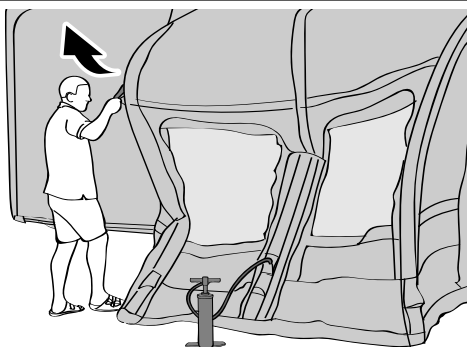
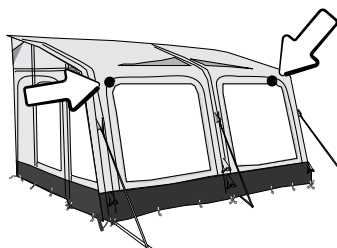

9

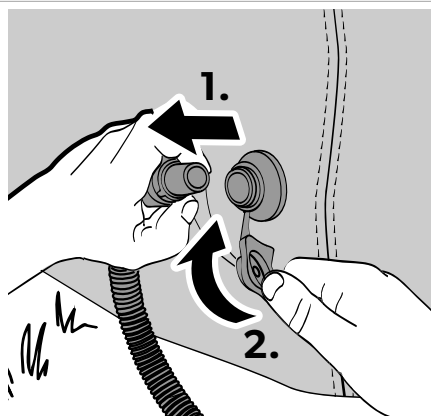
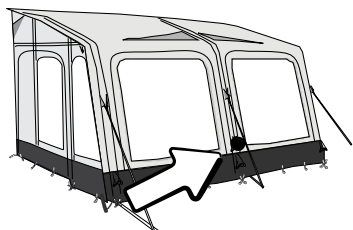

10

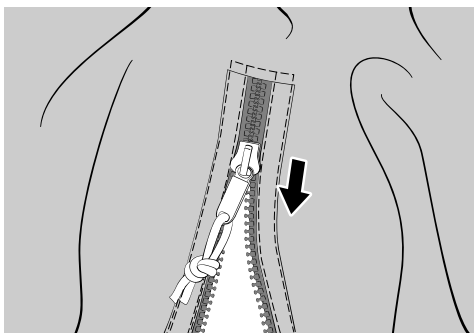
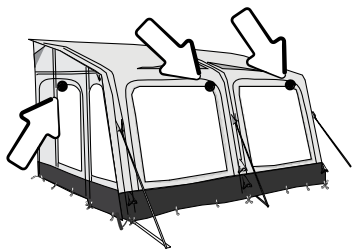

11

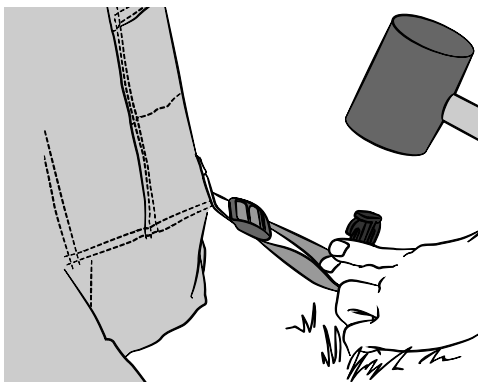
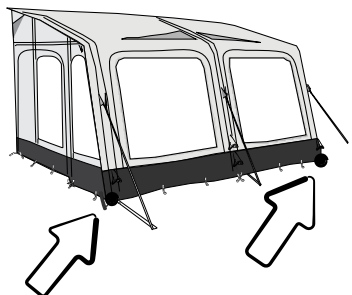

12

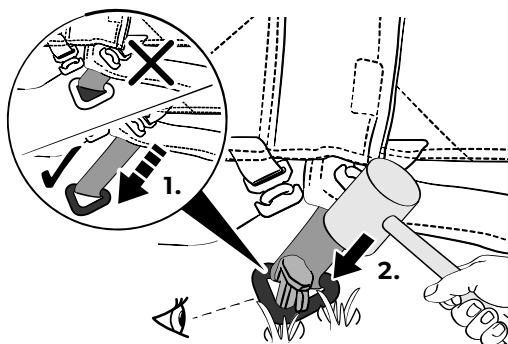

13

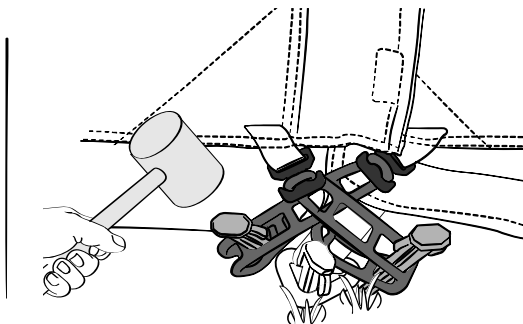
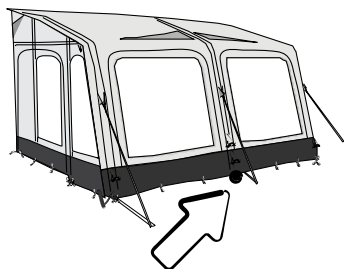

14

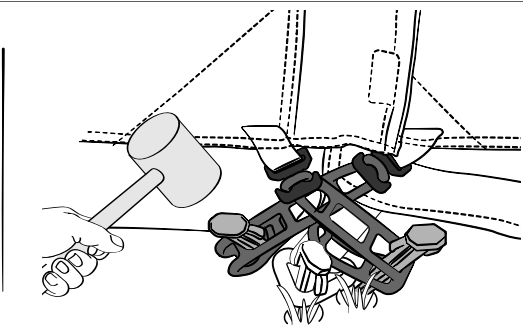
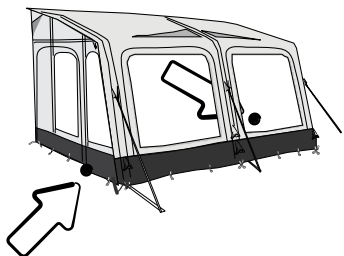

15

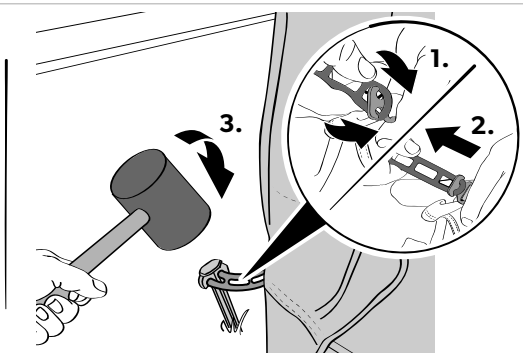
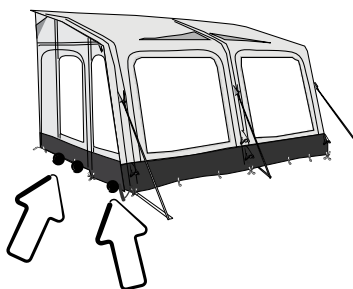

16

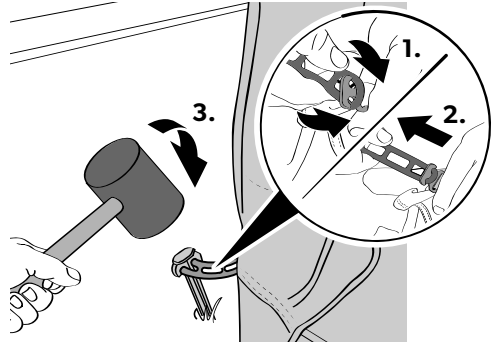
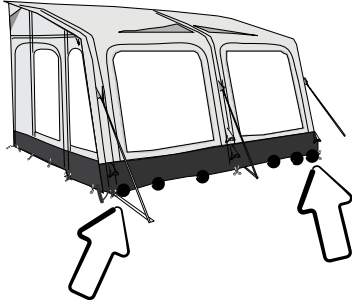

17

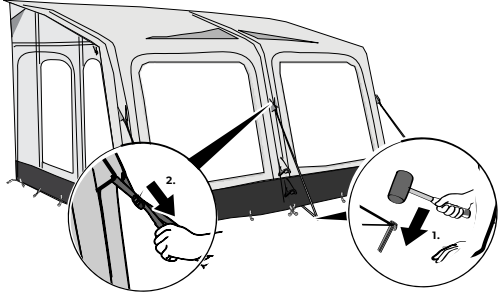

18



 9120002361 (Rally Tour)

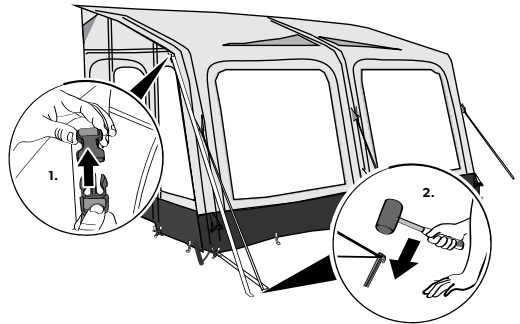

19

Rally AIR Tour DA,
Leggera AIR Tour DA

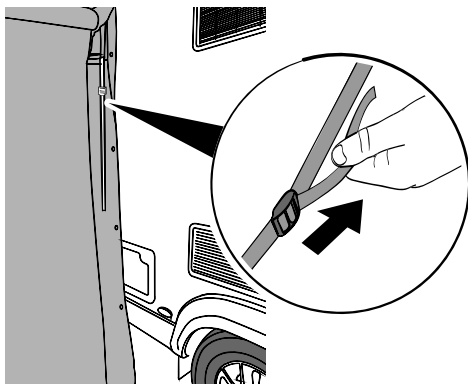
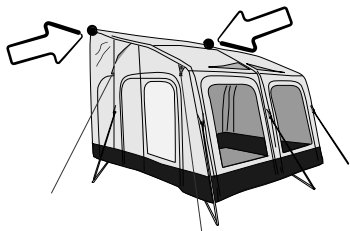

20

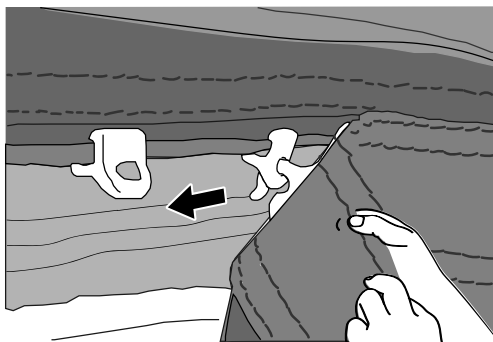
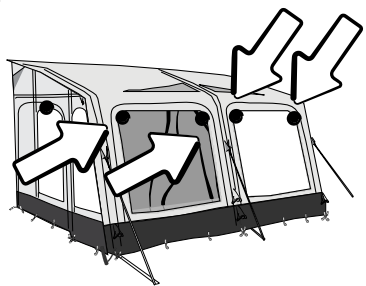

21

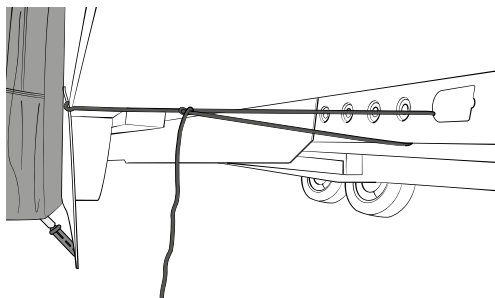
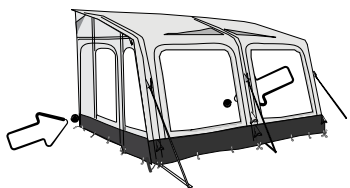

22

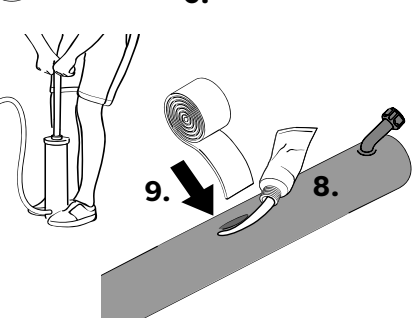
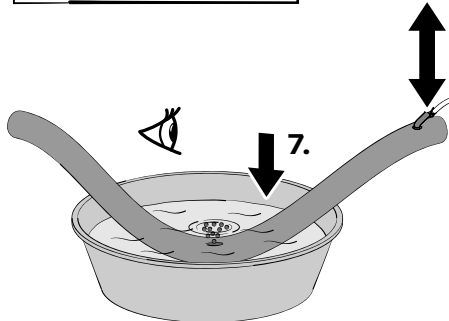
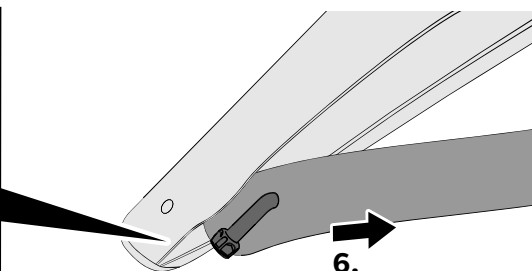
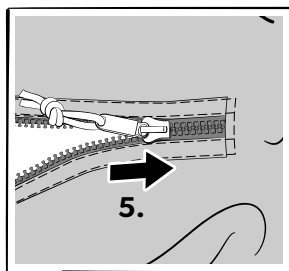
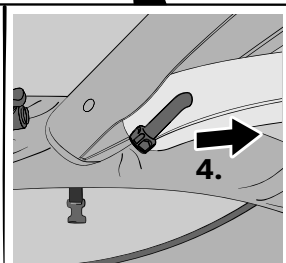
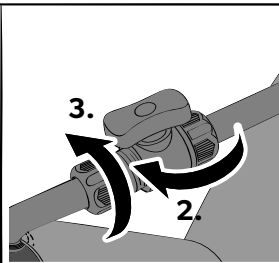
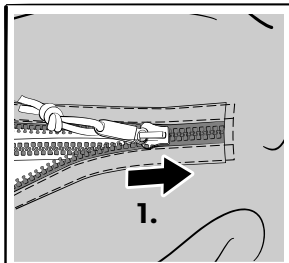
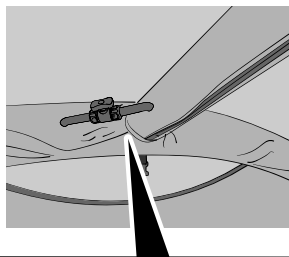
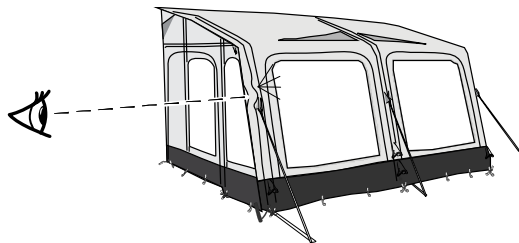

English

1 Copyright

© 2025 Dometic Group. The visual appearance of the contents of this manual is protected by copyright and design law. The underlying technical design and the products contained herein may be protected by design, patent or pending patent. The trademarks mentioned in this manual belong to Dometic Sweden AB. All rights are reserved.

2 Important notes

Please read these instructions carefully and follow all instructions, guidelines, and warnings included in this product manual in order to ensure that you install, use, and maintain the product properly at all times. These instructions **MUST** stay with this product.

By using the product, you hereby confirm that you have read all instructions, guidelines, and warnings carefully and that you understand and agree to abide by the terms and conditions as set forth herein. You agree to use this product only for the intended purpose and application and in accordance with the instructions, guidelines, and warnings as set forth in this product manual as well as in accordance with all applicable laws and regulations. A failure to read and follow the instructions and warnings set forth herein may result in an injury to yourself and others, damage to your product or damage to other property in the vicinity. This product manual, including the instructions, guidelines, and warnings, and related documentation, may be subject to changes and updates. For up-to-date product information, please visit documents.dometic.com.

3 Related videos



Find the “How To Set Up Your Motorhome Static Awning” video on qr.dometic.com/bfFUPz.



Find the “How To Set Up Your Motorhome Drive-away Awning” video on qr.dometic.com/bfFUxS.



Find the “How To Set Up Your Caravan Awning” video on qr.dometic.com/bfFV6O.

4 Explanation of symbols

A signal word will identify safety messages and property damage messages, and also will indicate the degree or level of hazard seriousness.



DANGER!

Indicates a hazardous situation that, if not avoided, will result in death or serious injury.



WARNING!

Indicates a hazardous situation that, if not avoided, could result in death or serious injury.



CAUTION!

Indicates a hazardous situation that, if not avoided, could result in minor or moderate injury.



NOTICE!

Indicates a situation that, if not avoided, could result in property damage.



NOTE Supplementary information for operating the product.

5 Safety instructions



DANGER! Hazard of carbon monoxide poisoning

Never use a fuel-burning appliance such as barbecues or gas heaters inside. The burning process produces carbon monoxide which accumulates inside as there is no flue.



WARNING! Fire hazard

- > KEEP ALL FLAME AND HEAT SOURCES AWAY FROM THE FABRIC.
- > If a fire occurs:
 - Leave the tent immediately.
 - Move to safe distance.
 - Ensure that you know the fire precaution arrangements on the site.
- > Do not cook inside or use open flames.



WARNING! Beware of suffocation

Ensure that ventilation openings are open all the time to avoid suffocation.



CAUTION! Risk of injury

- > This device is not intended for use by persons (including children) with reduced physical, sensory or mental capabilities, or lack of experience and knowledge, unless they have been given supervision or instruction concerning use of the device by a person responsible for their safety.
- > Do not allow children to play around and ensure that suitable protective footwear is worn. Guy lines are a trip hazard and pegs can be sharp.
- > Cleaning and user maintenance shall not be made by children without supervision.
- > Keep passage ways clear.

6 Scope of delivery

Component	Quantity		
	Grande / Rally / Club AIR Tour	Grande / Rally AIR Stay	Leggera AIR
Awning tent	1	1	1
Peg pack	1	1	1
Side panels	2	2	–
Front panels	2	2	–
Curtain set	1	1	–
Mist storm straps	–	2	2
Draught skirt (Size M excluded)	1	1	1
2.2 L pump	1	1	1
Carry bag	1	2	1
Installation and operating manual	1	1	1

Component	Quantity	
	Leggera AIR DA	Rally AIR Tour DA
Awning tent	1	1
Peg pack	1	1

Component	Quantity	
	Leggera AIR DA	Rally AIR Tour DA
2.2 L pump	1	1
6 m connection straps	3	3
Mist storm straps	2	–
Curtain set	–	1
Side panels	–	2
Front panels	–	2
Connection tunnel walls	–	2
Connection tunnel monsoon pole	–	1
Carry bag	1	2
Installation and operating manual	1	1

7 Accessories

Available as accessories (not included in the scope of delivery):

All	Ref. no.
Magnetic mesh side panel (not for Leggera AIR)	9120002439
Lighting system Sabre-Link 150	<ul style="list-style-type: none"> • Starter: 9120000337 (UK) / 9120000338 (EU) • Add-on: 9120000339
Veranda storm pole	9120002264
All AIR Tour	
Annexe (Tall)	9120002348
Annexe	9120002349
Conservatory	9120002350
Storm tie down kit mist	9120002361



NOTE Find the reference numbers for: canopies, extensions, mesh front panel, roof lining, continental carpet & footprint in **More accessories on page 2.**



NOTE For more accessories please visit dometic.com.

8 Intended use

This awning tent is suitable for the following applications:

- Motorhomes and caravans
- Light to moderate weather
- Touring

This awning tent is **not** suitable for the following applications:

- Very strong winds or snowfall
- Seasonal pitch or commercial use

This product is only suitable for the intended purpose and application in accordance with these instructions.

This manual provides information that is necessary for proper installation and/or operation of the product. Poor installation and/or improper operating or maintenance will result in unsatisfactory performance and a possible failure.

The manufacturer accepts no liability for any injury or damage to the product resulting from:

- Incorrect installation or assembly
- Incorrect maintenance or use of spare parts other than original spare parts provided by the manufacturer
- Alterations to the product without express permission from the manufacturer
- Use for purposes other than those described in this manual

Dometic reserves the right to change product appearance and product specifications.

9 Using the awning tent



CAUTION! Risk of injury and damage hazard

Never open the zipper on the protective sleeve while an air pole is inflated. This will result in the air pole bursting.



CAUTION! Health hazard and material damage

A poorly ventilated awning tent can develop condensation and mold.

- > Ensure the awning tent is always well ventilated.

- > Consider using a mesh panel set accessory for better ventilation.



NOTE

When attaching to fixed awning rails, the optional canopy, extension, annexes and conservatory can be used.

When attaching to cassette awning rails, it is recommended to **not** use the optional canopy, extension, annexes or conservatory.

9.1 Before first use

Before using the product for the first time, perform a test set-up to familiarize yourself with it. Check if the scope of delivery is complete.

9.2 Choosing a site

Choose a flat site that is protected from wind:

1. If necessary, use a windbreak.
2. Choose a shaded site to avoid UV degradation of the fabric.
3. Avoid pitching under trees as falling branches, resin, etc. can damage the product.
4. Clear the site of sharp stones and debris to avoid damaging the groundsheet.
5. Set up the product with the doors facing away from the wind.

9.3 Setting up the awning tent



CAUTION! Risk of injury and damage hazard

- > Do not use any type of compressor designed to inflate car tires.
- > Only inflate the air poles under control of a pressure gauge with a pressure of 9 psi (0.62 bar).



NOTICE! Damage hazard

- > Do not open or close the zippers by force.
- > If a wind-out awning is used to attach the awning tent, support the wind-out awning while working to avoid putting too much stress on it. After attaching the awning tent, rewind the wind-out awning fully back into its housing. This product should not be used with the cassette awning in its extended position.

**NOTE**

- The supplied pegs will be suitable for most sites but for some types of ground special pegs will be needed. Ask your dealer.
- Drive the pegs at a 45 ° angle away into the ground.
- Peg the guy lines in line with the seam it starts from.

Keep the following tips in mind while setting up the awning tent:

- The figures provide a general overview of the setup. The actual setup will vary slightly based on the model of awning tent.
- Get help. The setup is easier with more people.
- After standing the awning tent upright, check the corner pegs and re-peg if necessary. The groundsheet on the inside should be taut and in a rectangular shape.
- Peg the guy lines so that the awning tent is under tension without distorting the shape.
- If available, attach the storm tie down kit.
- Regularly check the guy lines to ensure adequate tension. If necessary, use the runners to adjust.

9.3.1 Preparing the setup

1. To protect the awning tent from dirt and damage lay down a groundsheet or footprint before unpacking.
2. Unpack the awning tent.
3. Separate and identify the different components.

9.3.2 Setting up

1. Attach the awning tent to your vehicle using one of the following methods:

- Insert the keder into the awning rail and pull the awning tent through to the desired location.

 **Fig. 1 on page 5**

- Insert the keder into the cassette awning channel and pull the awning tent through to the desired location.

 **Fig. 2 on page 5**

- **Rally AIR Tour DA and Leggera AIR Tour**

DA only: Throw the 6 m connection straps over the top of the vehicle and secure them by either pegging them into the ground or tying them to the vehicle's wheels.

 **Fig. 3 on page 5**

2. Secure the rear two corners by pegging the webbing straps about 5 cm under the vehicle.

 **Fig. 4 on page 6**

3. Inflate the awning tent:

- a) Close all deflation valves at the front of the awning tent.

 **Fig. 5 on page 6**

- b) Unscrew the top cap of the inflation valve (typically on the middle of the awning tent).

 **Fig. 6 on page 6**

- c) Insert the pump and inflate the air pole with a pressure between 3 psi and 4 psi initially.

 **Fig. 7 on page 7**

- d) Lift the awning tent from either side to help it take shape.

 **Fig. 8 on page 7**

- e) Continue inflating to 9 psi.

- f) Remove the pump and secure the top cap of the inflation valve.

 **Fig. 9 on page 7**

4. Secure the awning tent:

- a) Zip in all panels and close all doors.

 **Fig. 10 on page 8**

- b) Peg the front two corners in line with the rear corners, ensuring the awning walls are tensioned.

 **Fig. 11 on page 8**

- c) Peg the orange triangle on either side of the awning tent (adjust center legs if necessary).

 **Fig. 12 on page 8**

- d) Peg the middle leg on the front of the awning tent.

 **Fig. 13 on page 9**

- e) Cross-peg between doorways to reduce tension and ensure smooth zips.

 **Fig. 14 on page 9**

- f) Peg the intermediate pegging points on both sides.

 **Fig. 15 on page 9**

- g) Peg the remaining pegging points on the front of the awning tent.

 **Fig. 16 on page 10**

- h) Peg out the quick pitch guy lines and tighten them.

 **Fig. 17 on page 10**

- i) (Optional) Attach and peg the storm tie down kit.

 **Fig. 18 on page 10**

- j) **Rally AIR Tour DA and Leggera AIR Tour DA only:** Tension the straps connecting to the upper awning and tighten them.

 **Fig. 19** on page 11

5. **EXCEPT Leggera AIR Tour:** Hook the curtains into position.

 **Fig. 20** on page 11

You can find the production data on the label next to the fire regulation label inside the back of the awning.

6. **Grande AIR Tour, Rally AIR Tour, Leggera AIR Tour (except Size M), Grande AIR Stay, Rally AIR Stay, and Club AIR Tour only:** Attach the draught skirt:
- Secure the draught skirt to the awning rail at the bottom of your vehicle.
 - Tension the top corners by tying the ropes to the chassis.
 - Peg down and tighten the draught skirt using the webbing straps.

 **Fig. 21** on page 11

9.3.3 Dismantling the awning tent



NOTICE! Damage hazard

Do not use force when dismantling the awning tent. Otherwise you might damage any material.

- Remove any dirt on the outside.
- Close all windows blinds or remove curtains.
- Close all doors and openings.
- If installed, push the canopy pole out of the sleeve, do not pull.
- Remove all lines and straps.
- Remove all pegs between the corner pegs.
- Open the valves on each pole.
- Wait until most of the air has been expelled.
- Remove the four corner pegs.
- Fold/roll the awning tent towards the valves to expel more air.
- When deflated, roll the awning tent to fit into the carry bag.
- Ensure that all parts are clean before packing them into the carry bag.

- If the awning tent is wet or damp, dry fully as soon as possible.

10 Cleaning and maintenance



NOTICE! Damage hazard

- > Do not use sharp or hard objects or cleaning agents for cleaning.
- > Do not use alcohol based materials, chemicals, soap and detergents for cleaning.
- > Remove bird droppings and tree resin as soon as possible to avoid permanent damage to the material.

- If necessary, clean the product with clean water and a soft brush.
- Apply impregnation against water and UV radiation before each trip.

11 Storing the awning tent



CAUTION! Health hazard and material damage

A wet or damp awning tent will quickly develop mold. Mold can also develop if the awning tent is left up for long periods of time with poor ventilation.

- > Fully set up the awning tent for cleaning.
- > Choose a warm and sunny day for cleaning to ensure the material will dry thoroughly.

- Clean the awning tent.
- Fully air out the awning tent and ensure it is totally dry before packing away.
- Store in a well ventilated, dry place, away from direct sunlight.

12 Troubleshooting



NOTE

During first exposure to water there may be some moisture at the seams. Through this moisture the threads will swell and fill the holes that are created in the sewing process.

A fully equipped spare parts kit should include:

- Waterproofer
- Repair tape and repair solution
- Silicone grease for the zippers
- Spare pegs

All these spare parts can be purchased from any reputable caravan or camping dealer.

Problem	Suggested remedy
Awning tent inflates with difficulties	<ul style="list-style-type: none"> > Check that the valve is fully screwed into the air pole. > Check if the inflation tube is twisted at the valve. This may be indicated by noise. Untwist the inflation tube. > Check that the hand pump is working.
Part of the awning tent does not inflate or deflate	<ul style="list-style-type: none"> > Check that all isolation valves that connect the air poles are open.
Air poles are kinked	<ul style="list-style-type: none"> > Add more air (9 psi / 0.62 bar).
Air leak	<ul style="list-style-type: none"> > Check that the valve is fully screwed into the air pole and the ring seal is in place. > Check that the cap of the valve is done up tightly. > Check for punctures, see .
Water leak	<ul style="list-style-type: none"> > Check for leaky seams, damaged tapings, and moist areas.

Problem	Suggested remedy
	<ul style="list-style-type: none"> > If you cannot find any leaks, see . > If you find any leaks, apply seam sealant.
Rip in the fabric	<ul style="list-style-type: none"> > Use repair tape to seal the fabric. > Have repairs carried out by an authorized specialist.

12.1 Condensation

The product suffers from internal condensation if one or more of the following conditions apply:

- High air humidity
- High ground moisture
- A drop in temperature

Severe condensation can run down the inside of the roof and drip off ties, tapes and other internal fittings and can be mistaken for leaking.

- > Increase ventilation by opening doors and/or windows.
- > Ensure that the material is not permanently damp. If necessary, dry it completely to avoid mold growth.
- > Install a waterproof groundsheet in the porch area.

12.2 Repairing a puncture in the air pole

Fig. 22 on page 12

If the air pole loses air, proceed as follows:

1. Unzip the outer sleeve holding the air pole.
2. If installed, close isolation valves.
3. Remove the air pole.
4. Deflate the air pole.
5. Unzip the protective sleeve to expose the inflatable tube.
6. Blow some air into the inflatable tube.
7. Submerge the tube in water.
8. Locate the puncture.
9. Use repair tape and repair solution to seal the hole.
10. Zip the inflatable tube back into the protective sleeve.
11. Zip the air pole back into the outer sleeve.

13 Disposal



Place the packaging material in the appropriate waste bin wherever possible. This separation is necessary, as packaging is a valuable resource and improper disposal may impact human health and the environment.

14 Warranty

The statutory warranty period applies. If the product is defective, please contact the manufacturer's branch in your country (see dometic.com/dealer) or your retailer.

For repair and warranty processing, please include the following documents when you send in the device:

- A copy of the receipt with purchasing date
- A reason for the claim or description of the fault

Note that self-repair or nonprofessional repair can have safety consequences and might void the warranty.

Warranty conditions

The warranty covers manufacturing defects, materials and parts. The warranty does not cover fading of the cover and wear and tear due to UV radiation, misuse, accidental damage, storm damage, or permanent, semi-permanent or commercial use. It does not cover any resulting damage. Please contact your dealer for claims. This does not affect your statutory rights.

15 Technical data

See table on Technical data on page 4.