

 **DOMETIC**

**AWNINGS**

# **BOX AWNING WALL**

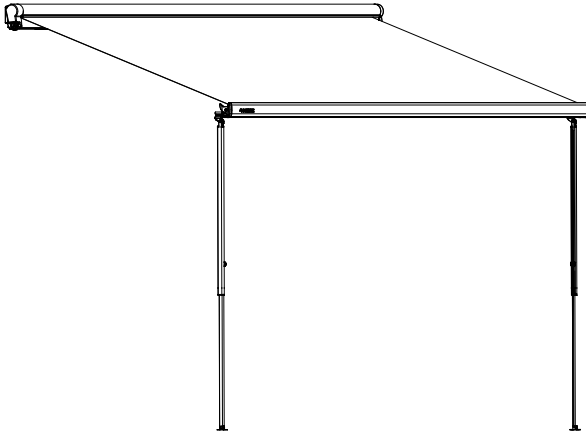

## **BAW3000**

<b>EN</b>	<b>Box awning</b>	
	Installation and Operating Manual.....	3

## Copyright

© 2025 Dometic Group. The visual appearance of the contents of this manual is protected by copyright and design law. The underlying technical design and the products contained herein may be protected by design, patent or pending patent. The trademarks mentioned in this manual belong to Dometic Sweden AB. All rights are reserved.

## English

1	Important notes.....	3
2	Related documents.....	3
3	Explanation of symbols.....	3
4	Safety instructions.....	4
5	Scope of delivery.....	6
6	Intended use.....	7
7	Installation.....	7
8	Operation.....	19
9	Cleaning and maintenance.....	27
10	Warranty.....	28
11	Disposal.....	29
12	Technical data.....	29

## 1 Important notes

Please read these instructions carefully and follow all instructions, guidelines, and warnings included in this product manual in order to ensure that you install, use, and maintain the product properly at all times. These instructions **MUST** stay with this product.

By using the product, you hereby confirm that you have read all instructions, guidelines, and warnings carefully and that you understand and agree to abide by the terms and conditions as set forth herein. You agree to use this product only for the intended purpose and application and in accordance with the instructions, guidelines, and warnings as set forth in this product manual as well as in accordance with all applicable laws and regulations. A failure to read and follow the instructions and warnings set forth herein may result in an injury to yourself and others, damage to your product or damage to other property in the vicinity. This product manual, including the instructions, guidelines, and warnings, and related documentation, may be subject to changes and updates. For up-to-date product information, please visit [documents.dometic.com](http://documents.dometic.com).

## 2 Related documents



Find this installation manual in more languages online at [qr.dometic.com/bgCrVZ](http://qr.dometic.com/bgCrVZ).

## 3 Explanation of symbols

A signal word will identify safety messages and property damage messages, and also will indicate the degree or level of hazard seriousness.



### **WARNING!**

Indicates a hazardous situation that, if not avoided, could result in death or serious injury.



### **NOTICE!**

Indicates a situation that, if not avoided, could result in property damage.



**NOTE** Supplementary information for operating the product.

## 4 Safety instructions



**NOTE** Observe the safety instructions and stipulations issued by the vehicle manufacturer and service workshops.

### General safety



**WARNING! Injury hazard**

If you do NOT have sufficient technical knowledge for installing components in vehicles, you should have a specialist fit the awning to your vehicle.



**WARNING! Injury hazard**

This device can be used by children aged from 8 years and above and persons with reduced physical, sensory or mental capabilities or lack of experience and knowledge if they have been given supervision or instruction concerning use of the device in a safe way and understand the hazards involved.

### Operating the awning safely



**WARNING! Injury hazard**

- > Do not touch moving parts while operating the awning. There is a danger of injuries from moving parts.
- > Do not open the awning while driving.
- > Do not open the awning in strong winds or snowfall.
- > Retract the awning if strong winds, prolonged heavy rain, or snowfall are imminent.
- > Ensure that water or snow does not accumulate on the fabric. Otherwise this could damage the awning and vehicle or the awning arms could collapse and cause severe injury or fatality.
- > Do not approach the awning in the following events:
  - If the awning was left open during heavy winds.
  - If pools of water have formed on the awning.
  - If snow has accumulated on the awning.
  - If any debris is on the awning fabric.
- > Do not leave the extended awning unattended. Retract the awning before leaving your location.
- > Keep a safe distance from the awning when having barbecues or open fires. The fabric can be damaged by heat or catch fire.



### **NOTICE! Damage hazard**

- > Park the motorhome or caravan in a location where debris (such as branches, leaves, or similar) cannot fall onto the fabric.
- > The fabric of the awning should remain taut at all times and not hang down at the edges. If the fabric hangs down, it may rub against the arms and become damaged. The fabric should not sag in the middle with long awnings.
- > Only retract the awning when the fabric is free of debris (such as branches, leaves, or similar). Otherwise, the awning may be damaged during retraction.
- > Keep the awning free of dirt to prevent abrasions, stains and mildew.
- > If the awning is wet, retract it only for safety reasons. Extend it again as soon as possible to allow drying and prevent mildew, stains, or color fading.
- > Never bend an awning arm or the cover down to drain water off the awning. Doing so can bend the awning and impair its function.
- > Do not hang any objects on the awning, on the front cover or the awning arms.
- > Do not use any sprays (e.g., insect repellent, hairspray) near the awning. This can soil the fabric or diminish its water-repellent properties.
- > If there is insufficient space above the door after mounting the awning, keep the door closed when retracting or extending the awning to prevent contact with the arms or front panel. The required space depends on the door design (width, swing, or sliding door) and the set awning angle of inclination.

### **Driving safely**



### **WARNING! Injury hazard**

- > Under NO circumstances should you exceed the maximum driving speed of 130 km/h.
- > Do not drive the vehicle if the fabric is damaged or torn, even if the awning is properly retracted. The awning arms are held in place by the fabric. If the fabric rips while driving, the awning may suddenly extend, leading to serious injury. Secure the awning to prevent sudden and unexpected extension while driving.
- > Adjust driving speed according to current conditions, including road type, speed bumps, wind and weather, traffic intensity, and applicable speed limits. If conditions become too severe, stop the journey.
- > Adjust your driving behavior (e.g., crosswind sensitivity, cornering, and braking) to accommodate potential changes in vehicle behavior due to the installed awning.
- > NEVER drive with the crank inserted. Remove the crank before starting your journey.
- > Ensure the awning is retracted and secure before driving.
- > Check the awning for damage (such as tension cracks in the plastic parts) before driving. Do NOT drive if any parts are damaged or broken.

## 5 Scope of delivery

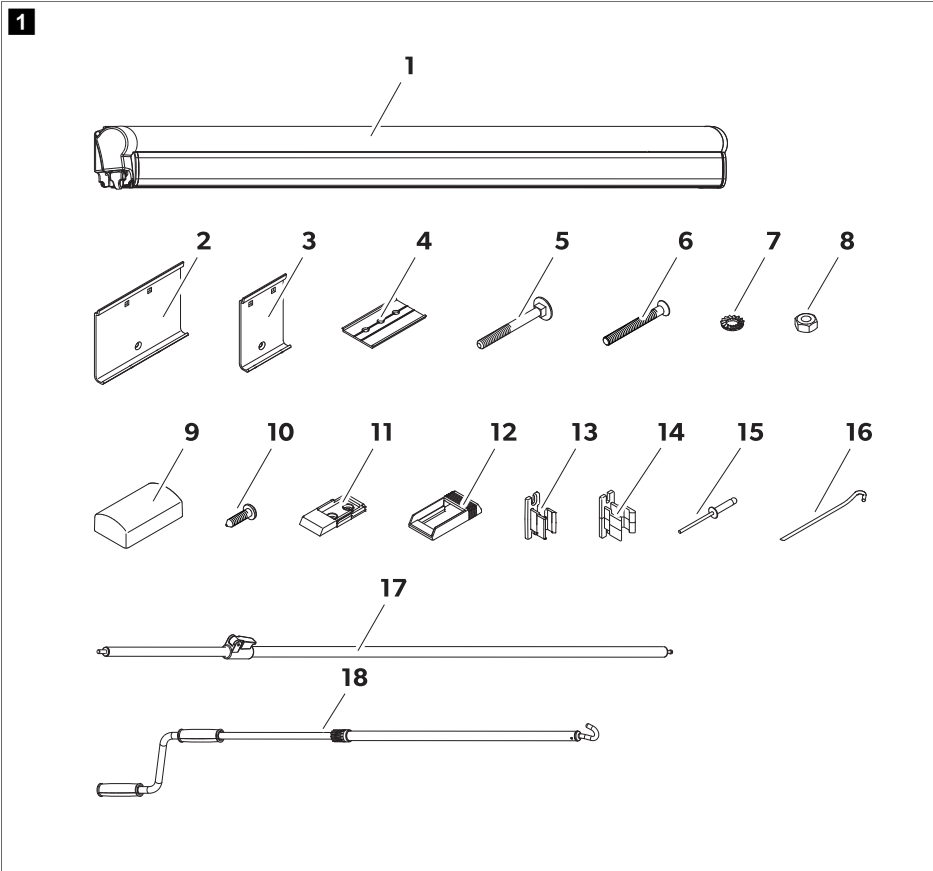

No. in the fig.  Fig. <b>1</b> on page 6	Items	Description	Awning width		
			2.6 m	3 m/3.5 m	4 m
1	Awning	-	1×	1×	1×
2	Mounting plate	160 mm	-	2×	2×
3	Mounting plate	80 mm	3×	1×	2×
4	Counter plate	-	6×	6×	8×
5	Square-head bolt	-	6×	6×	8×
6	Countersunk bolt	-	3×	3×	4×

No. in the fig.  Fig. 1 on page 6	Items	Description	Awning width		
			2.6 m	3 m/3.5 m	4 m
7	Serrated lock washer	-	9×	9×	12×
8	Hexagon nut	-	9×	9×	12×
9	Cover for the counter plate	-	6×	6×	8×
10	Self-tapping screw	-	12×	12×	18×
11	Mounting bracket	Lower section	2×	2×	2×
12	Mounting bracket	Upper section	2×	2×	2×
13	Lower bracket	Lower section	1×	1×	1×
14	Upper bracket	Upper section	1×	1×	3×
15	Rivets	-	4×	4×	4×
16	Pegs	-	4×	4×	4×
17	SRR (straight roof rafter)	Tension rafter	-	-	1×
18	Crank	-	1×	1×	1×

## 6 Intended use

The awning is intended for installation on motorhomes or caravans to provide shade and weather protection in moderate conditions; it should not be left out in harsh or heavy conditions.

The awnings must only be used whilst the vehicle is stationary.

This product is only suitable for the intended purpose and application in accordance with these instructions.

This manual provides information that is necessary for proper installation and/or operation of the product. Poor installation and/or improper operating or maintenance will result in unsatisfactory performance and a possible failure.

The manufacturer accepts no liability for any injury or damage to the product resulting from:

- Incorrect installation or assembly
- Incorrect maintenance or use of spare parts other than original spare parts provided by the manufacturer
- Alterations to the product without express permission from the manufacturer
- Use for purposes other than those described in this manual

Dometic reserves the right to change product appearance and product specifications.

## 7 Installation

### 7.1 Tools and materials required

- > Various tools for tightening, e.g. screwdriver
- > A suitable flexible adhesive/sealant, e.g. Sikaflex®-252
- > A cleaning agent that is recommended for use with the adhesive
- > A primer that is recommended for use with the adhesive
- > Acid-free silicone

## 7.2 Before installation



### **WARNING! Risk of death or serious injuries**

Whilst we do not design this awning to be used as a roof for an annex, if you choose to fit enclosed walls to the awning – a gas fitter should be consulted with regards to gas appliance venting and flueing.

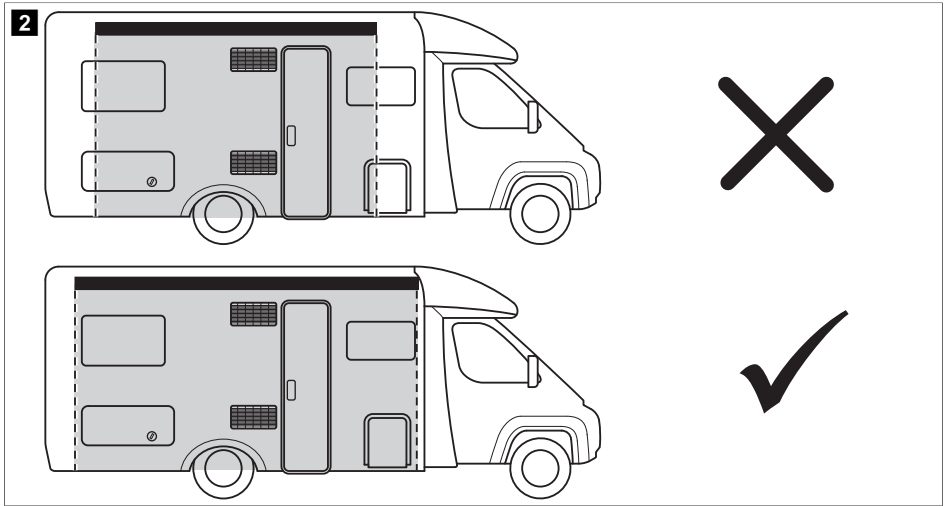

Observe the following general information:

- > The awning can be attached in two ways:
  - to the side of the vehicle using mounting plates (Installing the awning with mounting plates on page 11)
  - to the existing piping rail on the side of the vehicle (Installing the awning on the piping rail on page 14)
- > The mounting plates are bolted to the vehicle in the area of the rear hinge. In addition, they are glued with installation adhesive (e.g. Sikaflex®-221 or a similar product) to ensure the load is evenly spread and an optimal level of protection from moisture is maintained.
- > Observe the sealant manufacturer's instructions.
- > Before installation, check the access to the screw joints. Make sure no cables or cabinets are damaged when drilling.
- > Contact your local service partner if you wish to have an angle of inclination different to the default setting.
- > Clean the adhesive surfaces on the mounting rails and the wall.
- > Prepare the adhesive surfaces with the primer.
- > Carefully seal the drill holes to prevent moisture from entering the motorhome wall.
- > Do not open the awning or leave it unattended, before the awning has been fastened to the mounting rails.
- > As part of the regular maintenance procedure, the screws on the rear hinge must be tightened up by a service partner. Ensure the users of the vehicle are aware of this.



### 7.3 Installation position



#### WARNING! Property damage

- > Keep a sufficient distance from objects or other vehicles. Once the awning is retracted, it should be at least 40 cm away from other objects and vehicles.
- > Ensure the wall of the motorhome can safely take the weight of the awning before installation. Otherwise, the awning may become unstable and bend or break.

When choosing the installation location, observe the following:

- > Make sure that the inner screw joints are accessible.
- > Only attach the awning to flat and vertical wall surfaces (  Fig. 3 on page 9 and  Fig. 4 on page 9). On curved wall surfaces, specific mounting brackets are required, and the mounting plates need to be adequately lined under the fastening points.

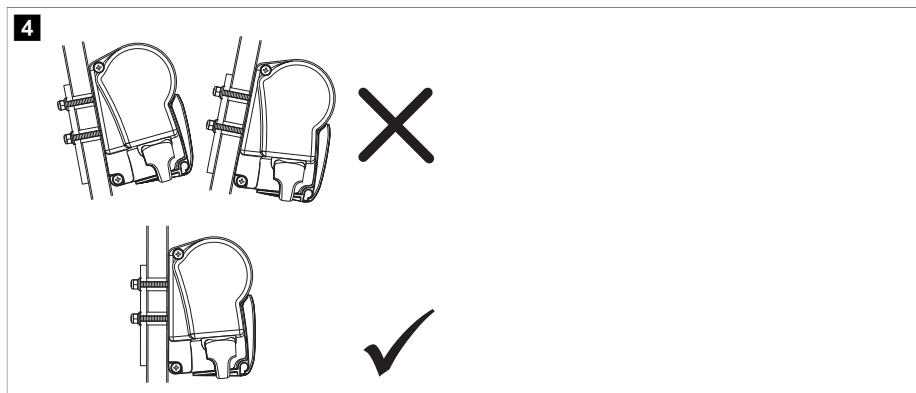
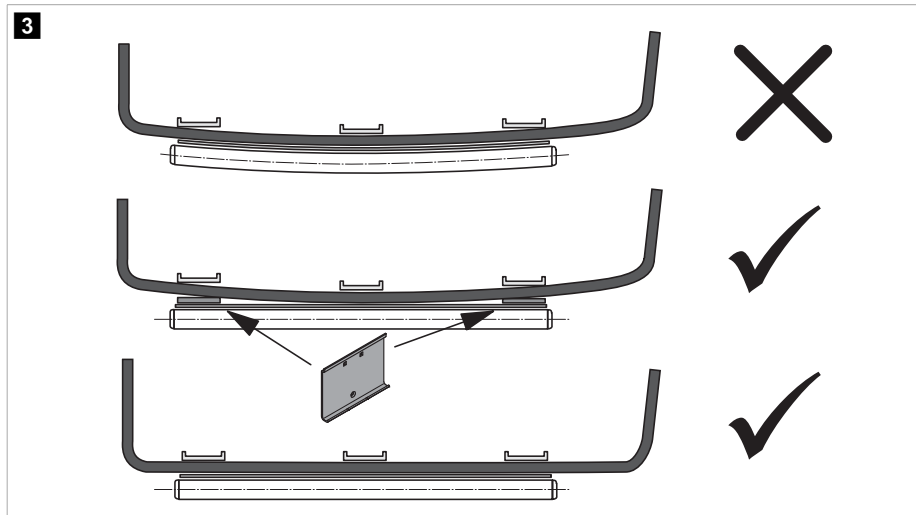

- > If there is insufficient space above the door after the awning is mounted, the door must remain closed when the awning is being retracted or extended to prevent contact between the door and the arms or lead rail. The required space depends on the design of the door (door width, swing or sliding door) as well as the set awning angle of inclination.

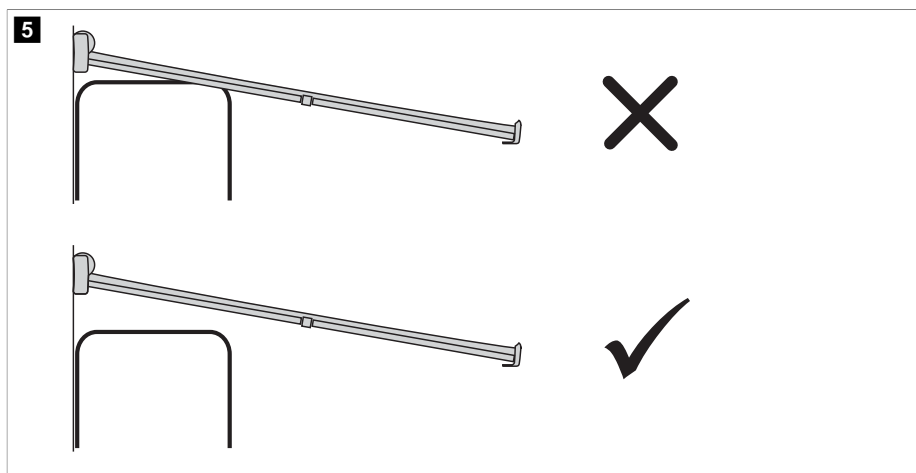
**CAUTION! Device damage**

The cables and cabinets in the interior of the vehicle must not be damaged by drilling the holes.

## 7.4 Installing the awning with mounting plates

1. Select the location of the installation.

In particular, check that there is enough space in the interior to mount the counter plates at the points where the screws will be.



**NOTE** Recommended mounting position for each counter plate is as shown (📷 Fig. 6 on page 11):

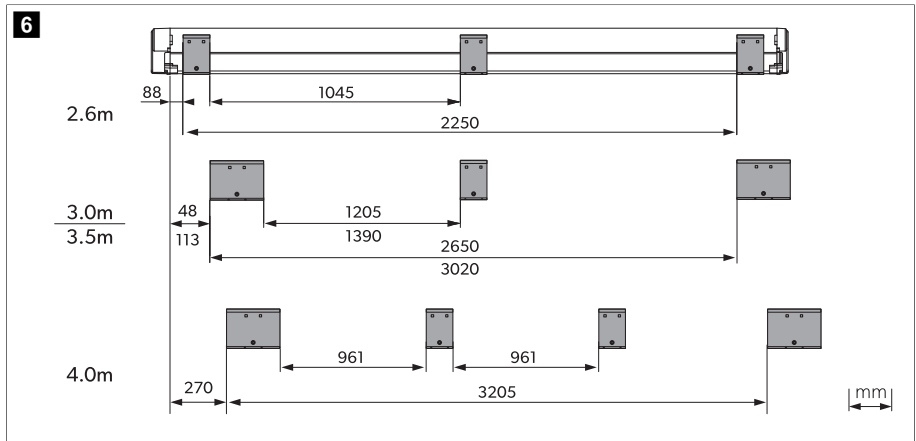

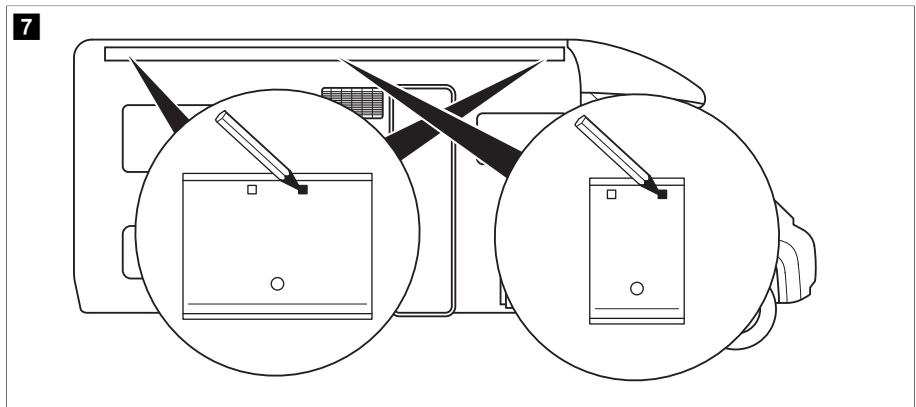

2. Align the mounting plates on the vehicle and mark where the holes are to be drilled (📷 Fig. 7 on page 11).

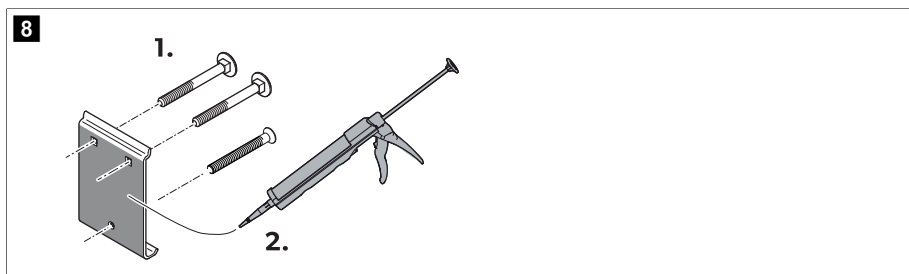

3. At the marked points, drill holes with a diameter of 6.5 mm from the outside through the external wall.
4. Clean the outer sides of the mounting plates and the installation surface on the vehicle.
5. Fill the drill holes in the vehicle wall with an acid-free silicone.

6. Insert the square-head bolts through the relevant holes in the mounting plates (  Fig. 8 on page 12).



7. To glue and seal, apply an elastic adhesive (such as Sikaflex®-221) to the back of the mounting plates (  Fig. 8 on page 12)
8. Place all of the mounting plates through the drill holes and fasten them with counter plate, serrated lock washers and hexagon head bolts (  Fig. 9 on page 12).

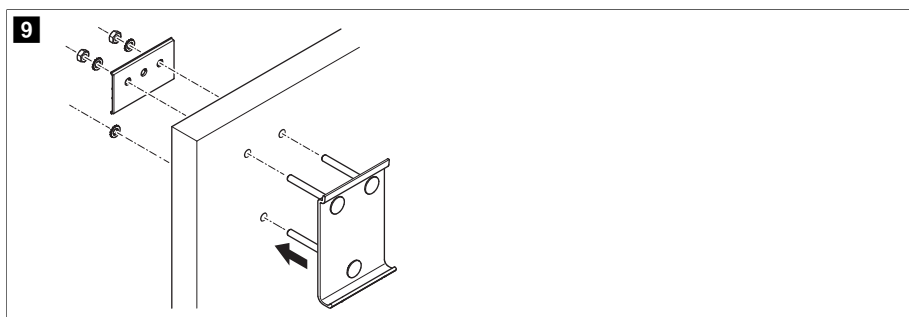

9. Fasten all the mounting plates using the fasteners provided. The fasteners may vary depending on the width of the awnings (see Scope of delivery on page 6).

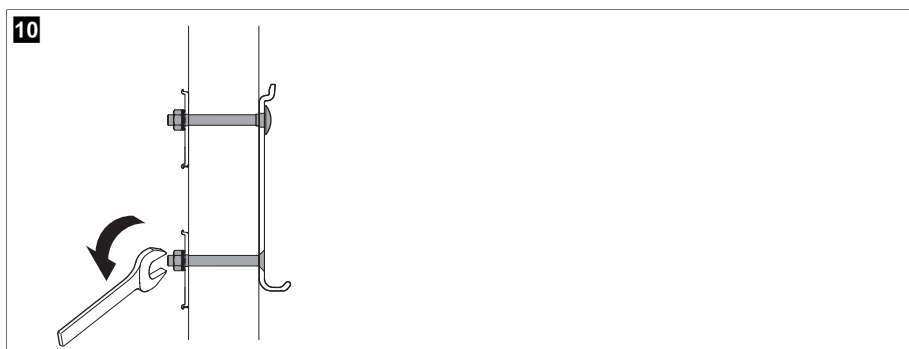

10. Wait until the glue has set. For further details, please refer to the information provided by the sealant manufacturer.

11. Use two people to hook the awning onto the mounting plates (  Fig. 11 on page 13).

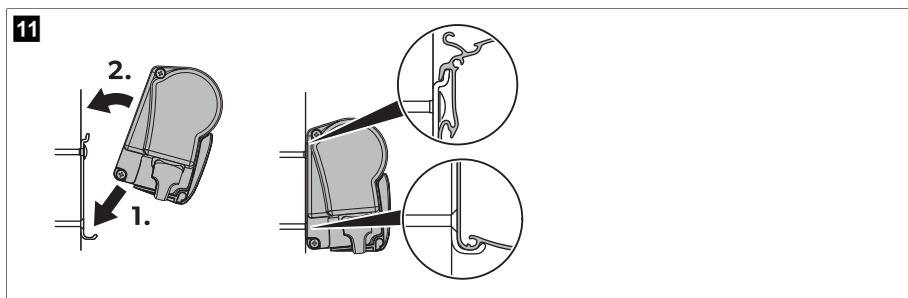

12. Extend the awning about 50 mm using the crank.

13. Drill holes for further securing the awning (step 1 in  Fig. 12 on page 13):

- Drill two 3 mm diameter holes through the awning, aligning them with the two holes on each of the long mounting plates.
- Drill one 3 mm diameter hole through the awning, aligning it with the hole on each of the short mounting plates.

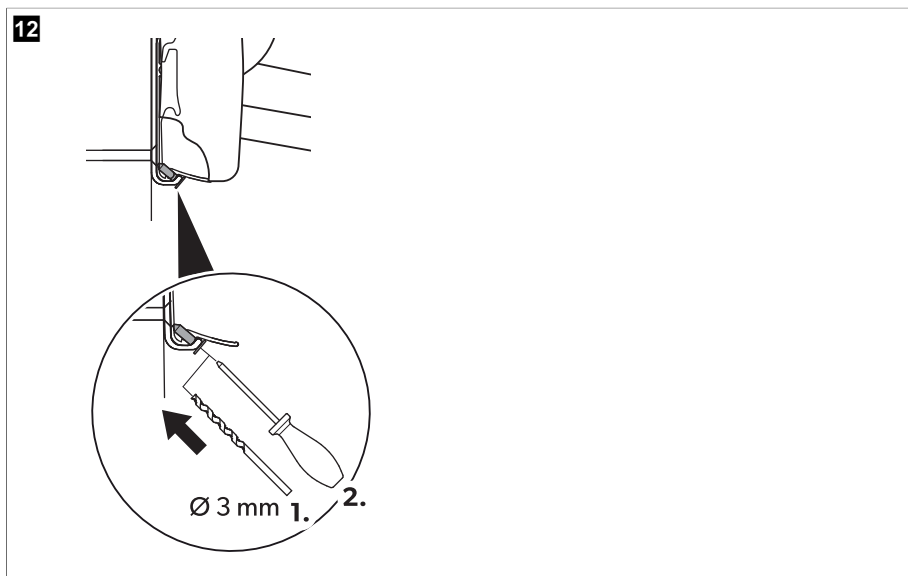

14. Fasten the awning with self drilling and tapping screws (step 2 in  Fig. 12 on page 13).

15. Insert the cover caps on the counter plates (  Fig. 13 on page 14).



**NOTE** The wall thickness must be at least 35 mm; otherwise, it is necessary to shorten the bolt if you choose to fit the cover cap.

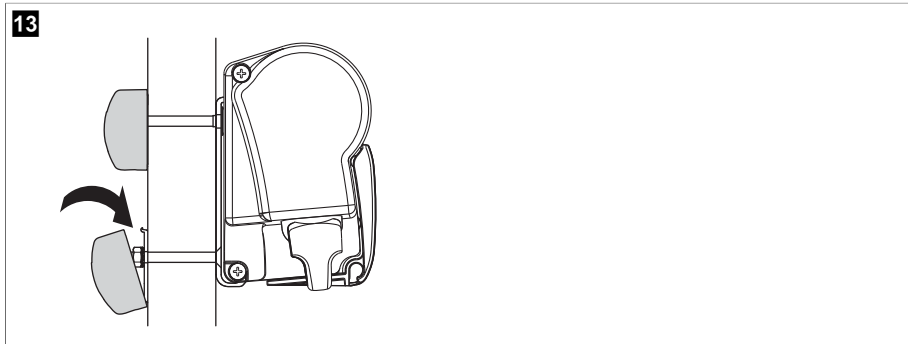

16. Retract the awning completely using the crank.

## 7.5 Installing the awning on the piping rail

1. Select the installation location.

In particular, check that there is enough space in the interior to mount the counter plates at the points where the screws will be.



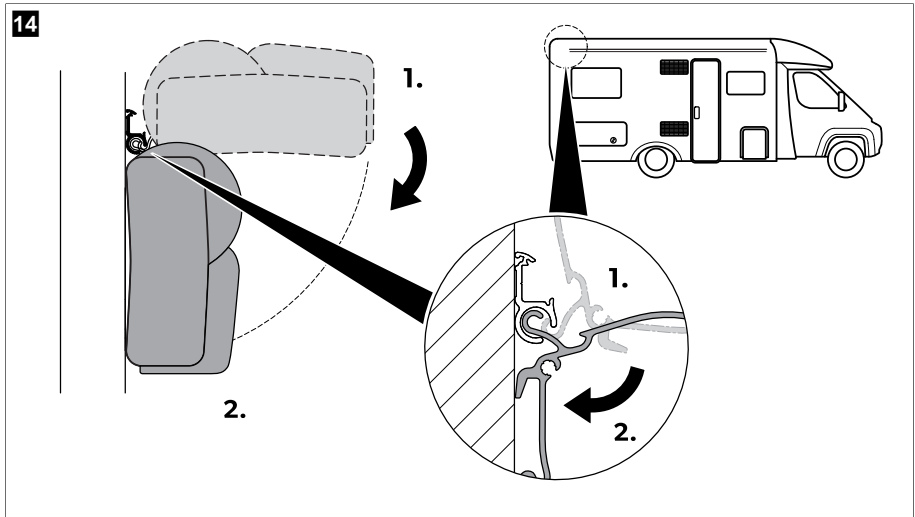

**NOTE** Measure the recommended mounting position for each counter plate against the drill hole in the lower section of the awning.

2. Use two people to hook the awning on to the piping rail (  Fig. 14 on page 15).



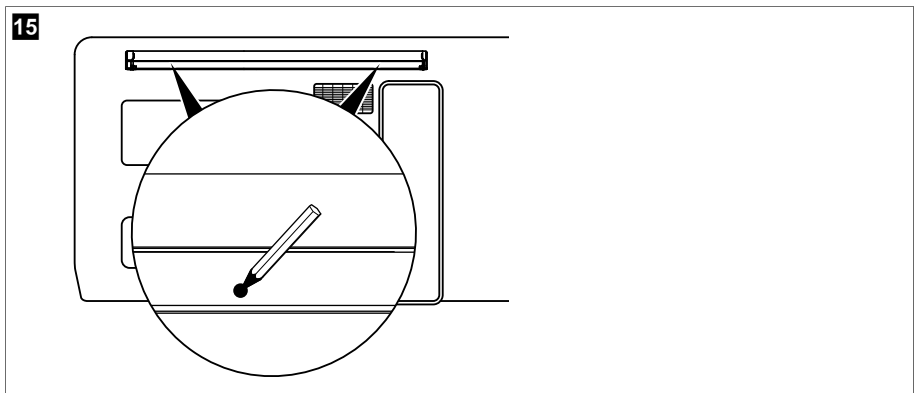

3. Extend the awning about 50 mm using the crank.  
 4. Mark where the holes are to be drilled (  Fig. 15 on page 15).

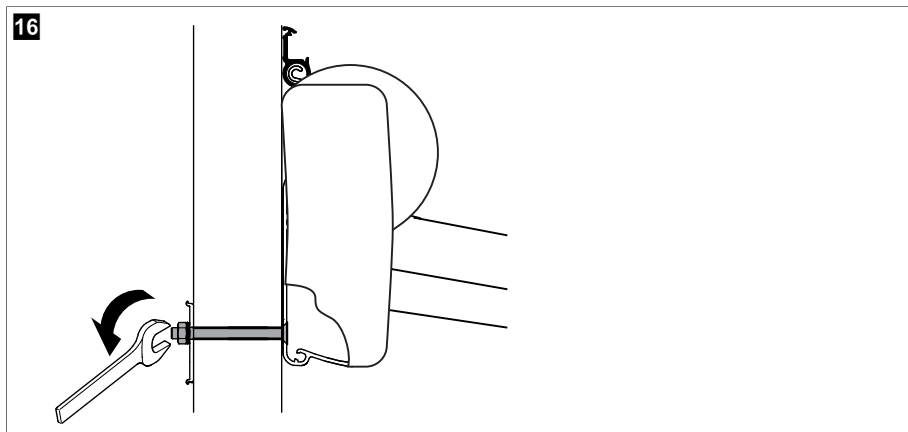

5. Retract the awning completely using the crank.  
 6. Use two people to lift the awning off the piping rail.  
 7. At the marked points, drill holes with a diameter of 6.5 mm from the outside through the external wall.  
 8. Fill the drill holes in the vehicle wall with an acid-free silicone.  
 9. Use two people to hook the awning on to the piping rail (  Fig. 14 on page 15).  
 10. Extend the awning about 50 mm using the crank.

11. Fasten the awning using a countersunk bolt, counter plate, serrated lock washer and hexagon nut (  Fig. 16 on page 16).



12. Insert the cover caps on the counter plates. (  Fig. 13 on page 14)
13. Retract the awning completely using the crank.

## 7.6 Installing the mounting bracket



**NOTE** The mounting bracket must be installed if the awning is to be attached to the side of the vehicle when extended.

1. Select the installation location.
2. Mark where the holes are to be drilled.

3. At the marked points, drill holes with a diameter of 3 mm from the outside into the external wall (step 1 in  Fig. 17 on page 17).

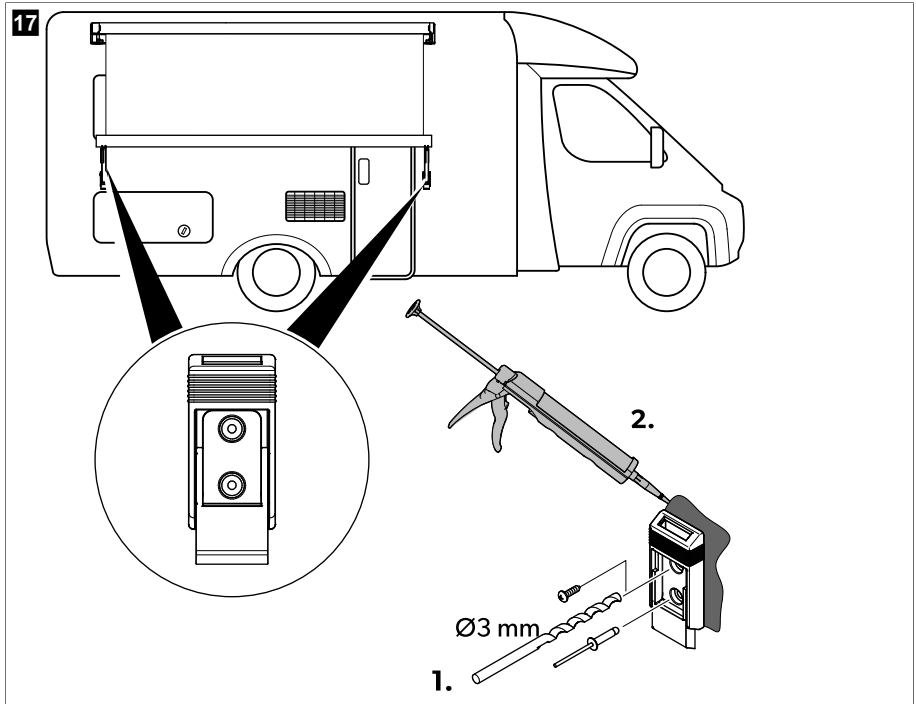

4. Put the upper and lower sections of the mounting bracket together.  
 5. Clean the outer sides of the lower section and the installation surface in the vehicle.  
 6. To glue and seal, apply an elastic adhesive (such as Sikaflex®-221) to the back of the mounting bracket (step 2 in  Fig. 17 on page 17).



**NOTE** Make sure that no glue gets on to the movable upper section of the mounting bracket.

7. Fasten the mounting bracket with drill screws or rivet the mounting bracket.

## 7.7 Installing the crank bracket

- > Install one upper and one lower bracket on the interior wall of the vehicle at a suitable location to securely hold the crank when not in use.

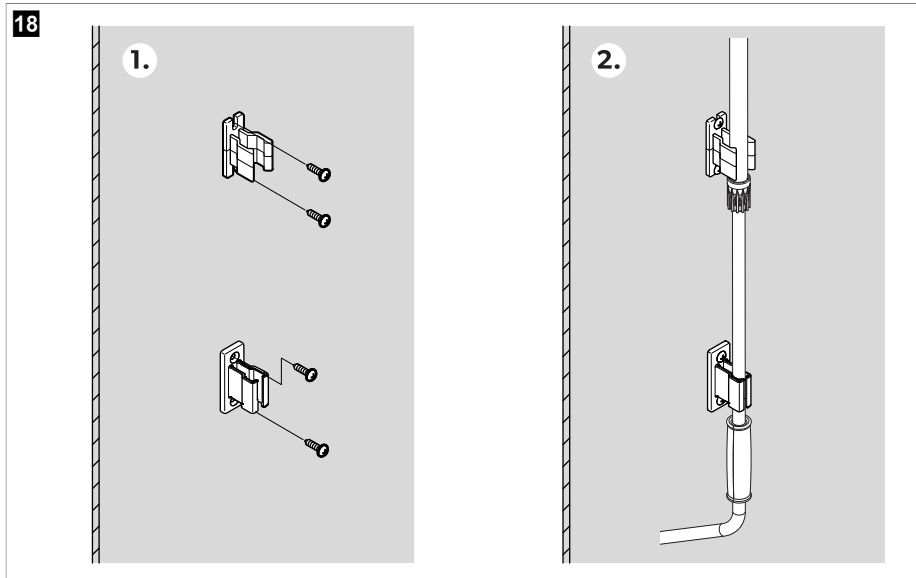

## 7.8 Installing the SRR bracket

- > Install two upper brackets on the interior wall of the vehicle at an appropriate location to securely hold the SRR (straight roof rafter) when not in use.

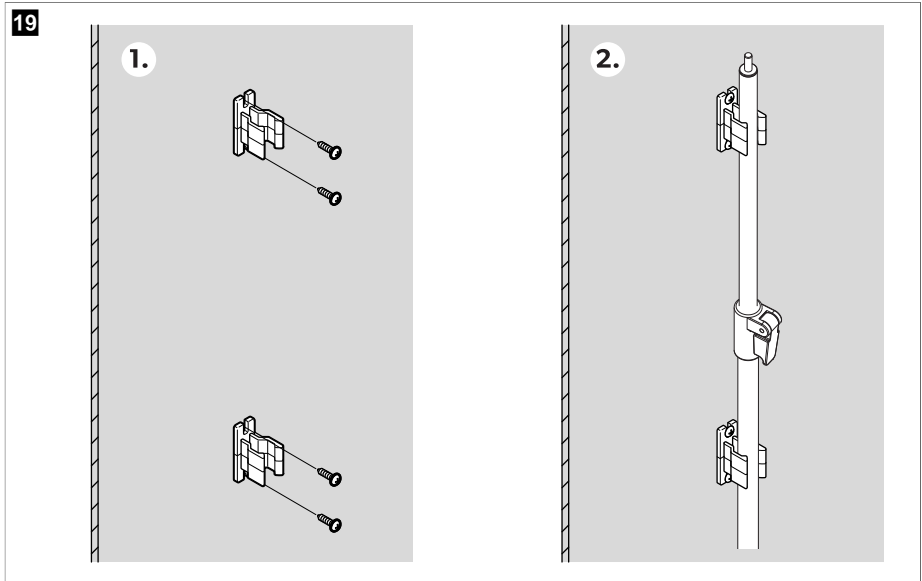

## 8 Operation

### Note on the vehicle location



#### NOTICE! Damage hazard

- > Park the vehicle so that no debris (branches, leaves or similar) gets on to the fabric.
- > Keep the awning free of dirt to prevent abrasions, stains and mildew.

### 8.1 Extending the awning



#### WARNING! Risk of injury

Keep a sufficient distance from objects or other vehicles. Once the awning is retracted, it should be at least 40 cm away from other objects and vehicles on all sides.

**Extending the awning using a hand crank**

1. Hook the hand crank into the crank socket of the awning (step 1 in  Fig. 20 on page 20).

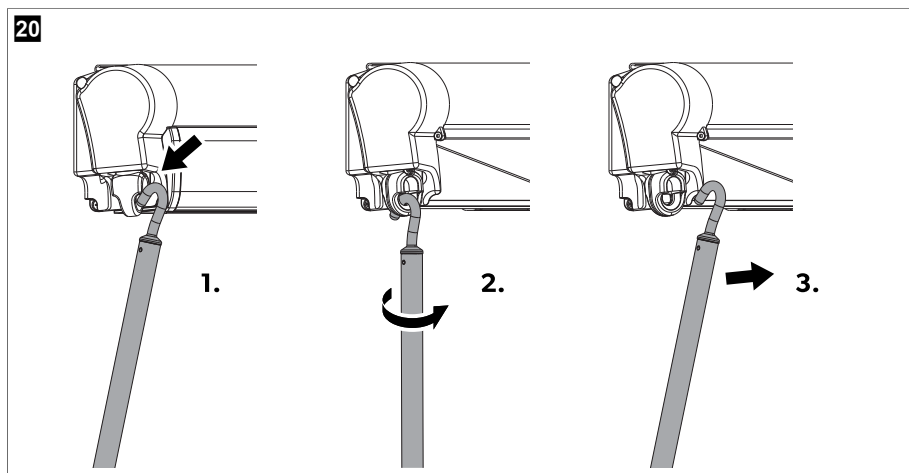

- Turn the hand crank to extend the awning.

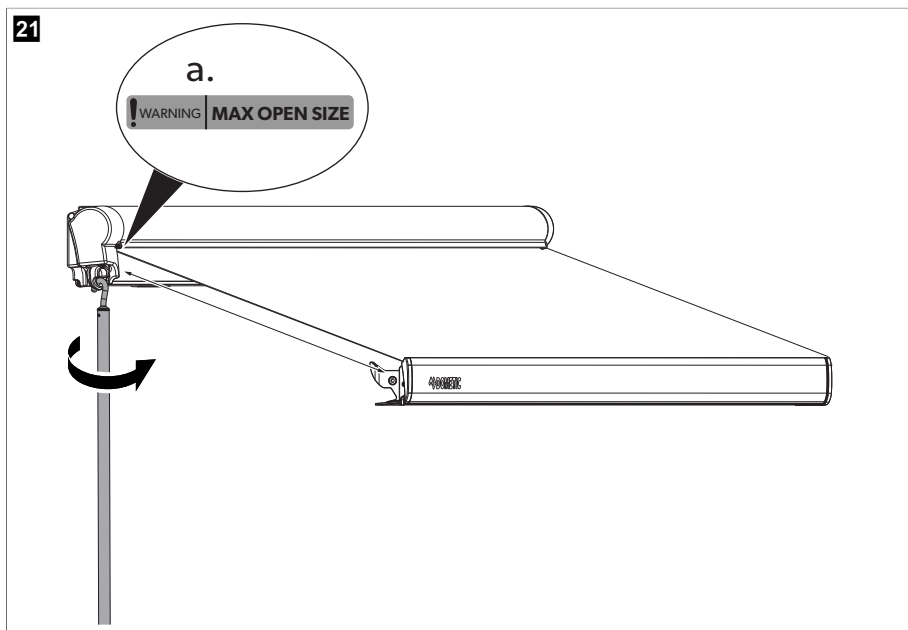

**WARNING! Damage hazard**

Stop extending the awning when the warning sticker (**a.** in  Fig. **21** on page 21) appears.

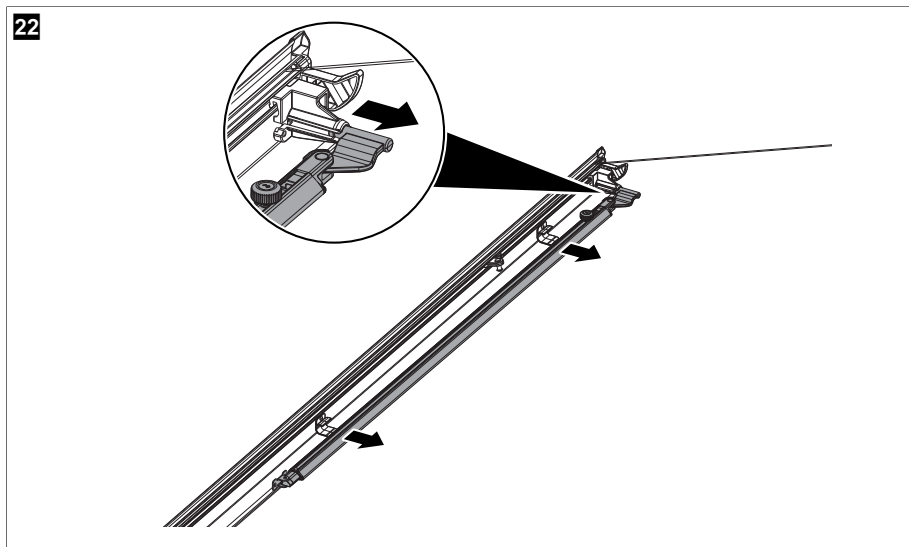

3. Extend the right supporting leg from the front cover for free movement (  Fig. 22 on page 22).



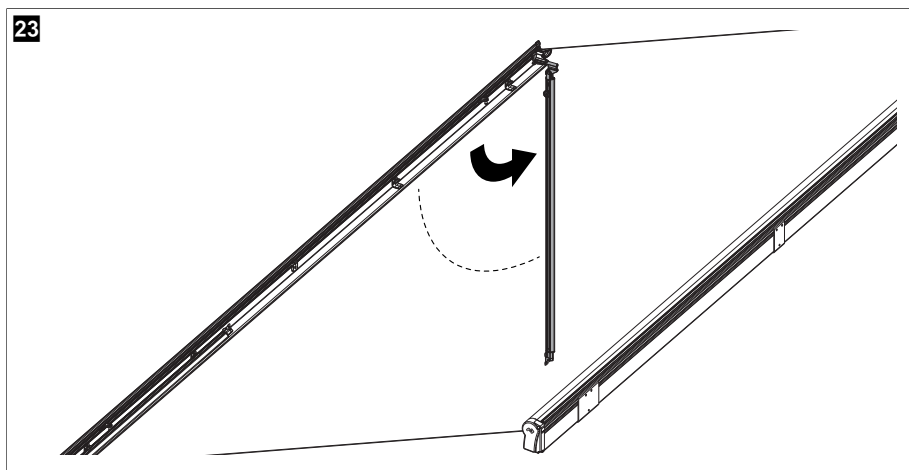

4. Turn the right supporting leg to the side (  Fig. 22 on page 22).
5. Fold the right supporting leg down and set it on the ground (  Fig. 23 on page 22).

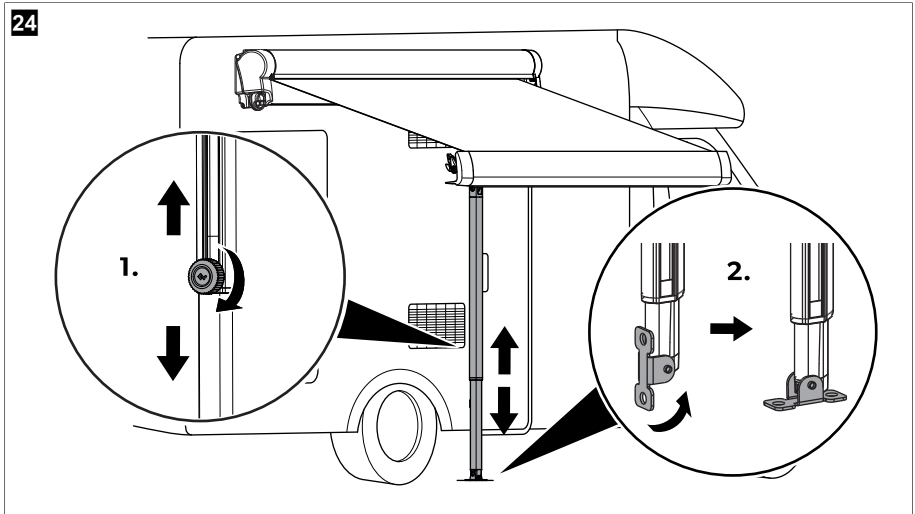

6. Adjust the supporting leg to the required height and manually tighten the nut on the supporting leg to secure its height (  Fig. 24 on page 23 ).



7. Rotate the kickstand of the supporting leg to secure the supporting legs on the ground (  Fig. 24 on page 23 ).
8. Extend the other supporting leg in the same way.
9. Turn the hand crank approximately a quarter of the way back to tighten the fabric.
10. Remove the hand crank. (step 3 in  Fig. 20 on page 20)



**NOTICE! Damage hazard**

- > The fabric of the awning should not hang down at the edges, and must remain taut at all times. If the fabric hangs down, it could rub against the arms and become damaged.
- > The fabric used for long awnings should not sag in the middle.

**Positioning the supporting legs on the ground**



**WARNING! Beware of injury**

- > Only position the supporting legs on solid ground.
- > Secure the supporting legs from slipping.

1. Position the supporting legs vertically on the ground (  Fig. 24 on page 23 ).

2. Secure the supporting legs with pegs.

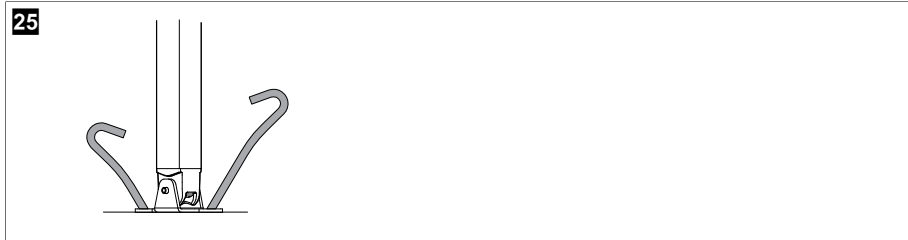

3. Position one of the supporting legs slightly lower so that the lead rail hangs at an angle. This allows rain to run off more easily.

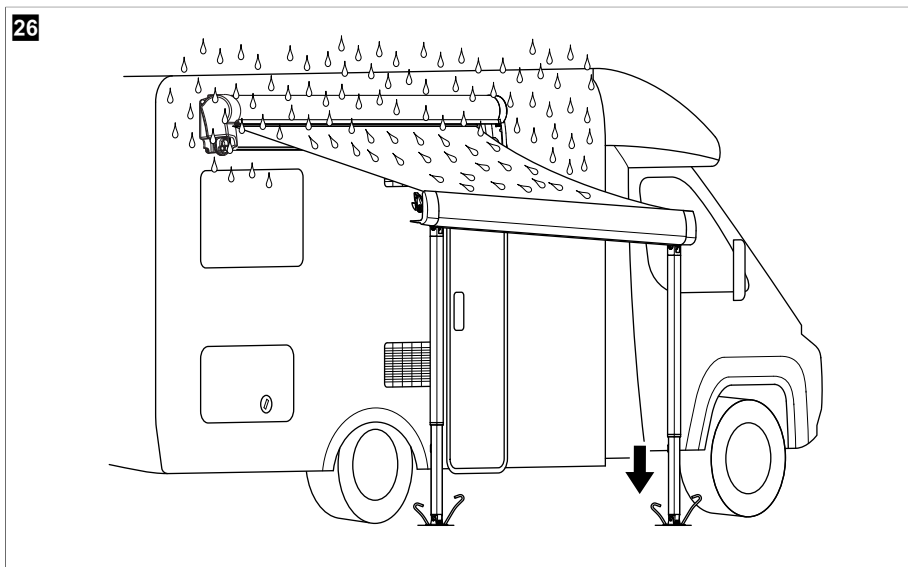



### Securing the supporting legs on the vehicle

You can secure the awning on your vehicle directly if you have already installed the mounting bracket. (📷 Fig. 17 on page 17)

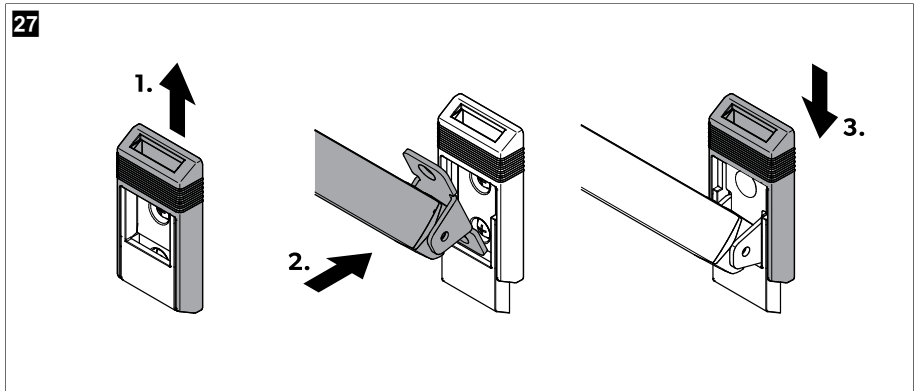
1. Slide the cover of the mounting brackets up (  Fig. 27 on page 25).



2. Fit the supporting legs into the mounting brackets (  Fig. 27 on page 25).
3. Slide the cover of the mounting brackets down (  Fig. 27 on page 25).
4. Position one of the supporting legs slightly lower so that the lead rail hangs at an angle. This allows rain to run off more easily (  Fig. 28 on page 25).

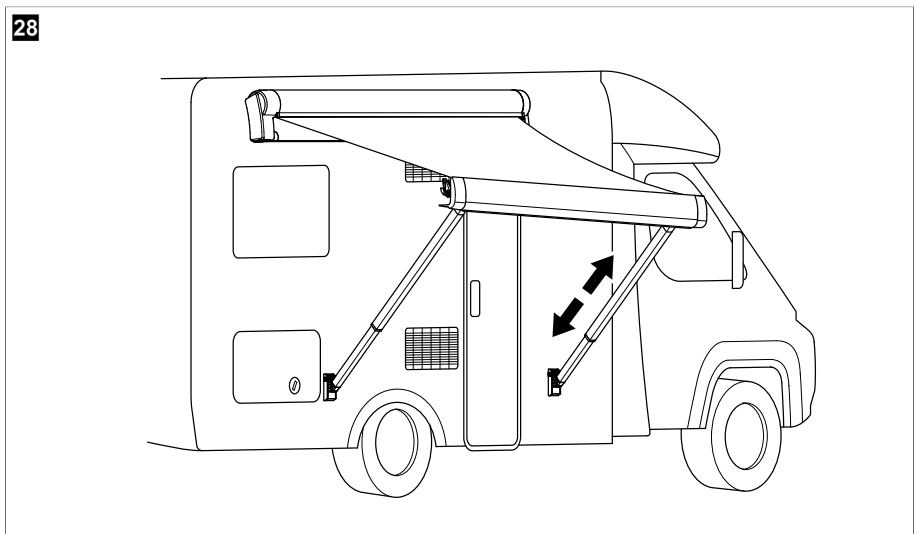

### Mounting the tension rafter

Awnings with a width of 4 m need to have a tension rafter fitted in the middle of the awning. This prevents the awning from sagging.

1. Extend the awning to your desired length by turning the crank.
2. Adjust the length of the tension rafter to match the extended awning.

3. Position the tension rafter in the middle of the inside of the awning, ensuring both ends are securely inserted onto the awning bars (  Fig. 29 on page 26).

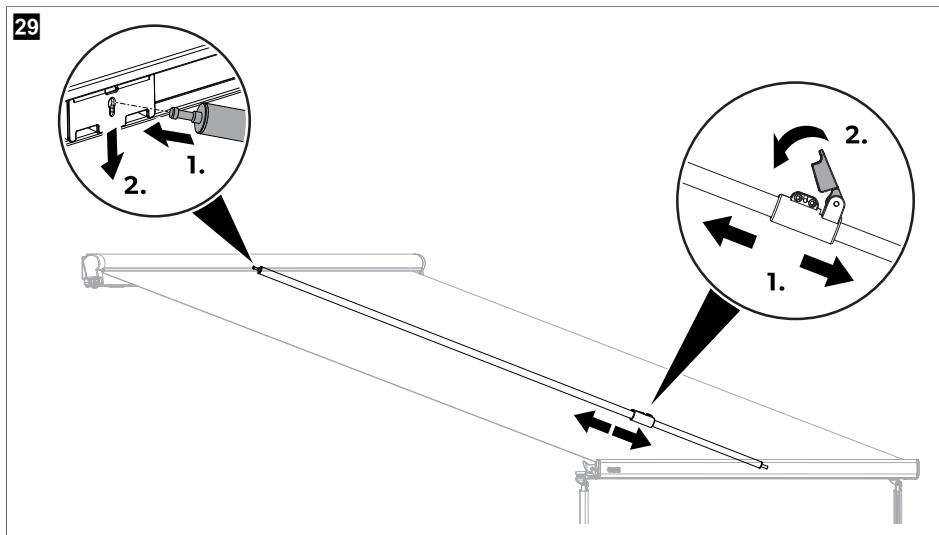

## 8.2 Retracting the awning



### **NOTICE! Damage hazard**

- > Only retract the awning when the fabric is free of debris (branches, leaves or similar). Otherwise the awning may be damaged when it is retracted.
- > Keep the awning free of dirt to prevent abrasions, stains and mildew.
- > When retracting the awning, make sure that no branches or other objects are trapped in it.

1. Remove any debris (branches, leaves or similar) lying on the fabric.
2. Loosen the supporting legs from the fastenings (pegs or latches on the vehicle).

## Retracting the awning using a hand crank

1. Loosen the nut on the supporting leg to fully retract the supporting leg, then tighten the nut.

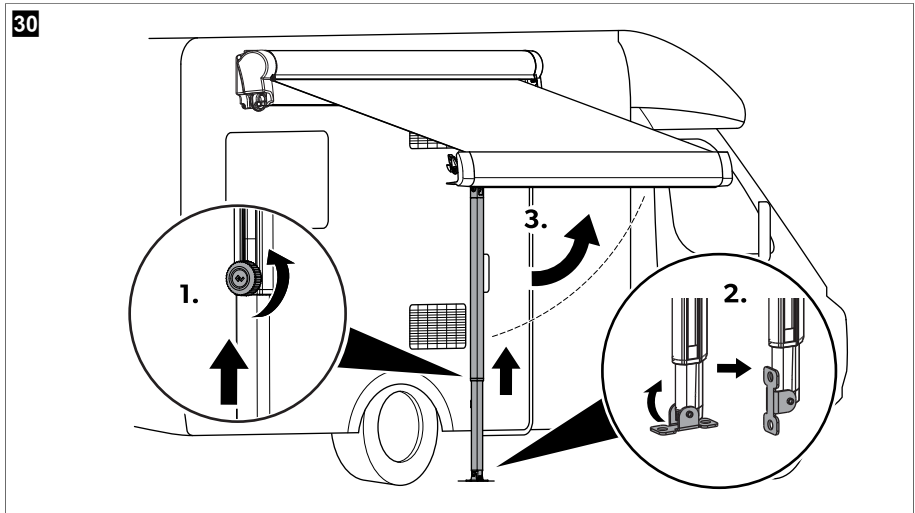

2. Rotate the kickstand at the end of the supporting leg.
3. Rotate the supporting leg to reposition it into the awning.
4. Push the supporting leg back into the awning front cover until it is securely in place.
5. Retract the other supporting leg in the same way.
6. Hook the hand crank into the crank socket of the awning (step 1 in  Fig. 20 on page 20).
7. Turn the hand crank in the opposite direction until the awning is fully retracted.
8. Ensure the awning is fully retracted and secure before starting your journey.



**NOTE** The lead rail must be right up against the housing.

9. Remove the hand crank from the crank socket of the awning.



### **NOTICE! Damage hazard**

If the awning is retracted while wet, extend it and allow the fabric to dry at the next opportunity. Prolonged storage of wet fabric can lead to mildew formation and fabric fading.

## 9 Cleaning and maintenance

### 9.1 Cleaning



### **NOTICE! Damage hazard**

- > Never clean the awning with a high-pressure cleaner.
- > Do not use abrasive cleaning agents or hard objects during cleaning, as these can damage the product.

- > Remove any debris (twigs, leaves or similar) lying on the awning fabric to prevent abrasions, stains and mildew. The awning can also be damaged when it is retracted.
- > Clean the awning fabric regularly to remove any dirt and dust:
  - a) Use water with 30 mL detergent and 30 mL bleach for 10 L of water.
  - b) Soap down the fabric and leave the liquid to soak in for five minutes.
  - c) Rinse thoroughly with clean water.



**NOTE** Make sure that the detergent with the bleach is completely washed off. Otherwise it can damage the fabric.

- d) Leave the fabric to dry.

## 9.2 Lubricating

If there is an abnormal sound, apply paraffin wax, teflon oil, or silicone oil on the arm joints.

## 9.3 Checking



### **WARNING! Injury hazard**

- > Do not use the awning if any settings or maintenance work are required.
- > If you discover any damage, contact a service partner in the respective country (see addresses and website details on the back of the manual).



**NOTE** Dometic accessories, such as sealing joints and foam strips, are subject to environmental wear and tear. This is not indicative of poor quality. To ensure these parts function properly, Dometic recommends replacing rubber seals and foam strips every 5 years or as required.

- > Check the awning regularly for any imbalance and wear, as well as damage to major parts.
- > Check the awning regularly:
  - Is the fabric free of damage?
  - Are the arms and lead rail free of damage with no signs of wear?
  - Does the awning close properly?

## 10 Warranty

If the product does not work as it should, please contact your retailer or the manufacturer's branch in your country (see [dometic.com/dealer](http://dometic.com/dealer)). The warranty applicable to your product is 1 year(s).

For repair and warranty processing, please include the following documents when you send in the device:

- A copy of the receipt with purchasing date
- A reason for the claim or description of the fault

Note that self-repair or nonprofessional repair can have safety consequences and might void the warranty.

### **Australia Only**

Our goods come with guarantees that cannot be excluded under the Australian Consumer Law. You are entitled to a replacement or refund for a major failure and for compensation for any other reasonably foreseeable loss or damage. You are also entitled to have the goods repaired or replaced if the goods fail to be of acceptable quality and the failure does not amount to a major failure. The benefits provided to you as the consumer by this warranty are in addition to other rights and remedies available to you under the law.

### New Zealand Only

This warranty policy is subject to the conditions and guarantees which are mandatory as implied by the Consumer Guarantees Act 1993(NZ).

#### 10.1 Warranty conditions

The warranty covers manufacturing defects, materials and parts. The warranty does not cover fading of the cover and wear and tear due to UV radiation, misuse, accidental damage, storm damage, or permanent, semi-permanent or commercial use. It does not cover any resulting damage. Please contact your dealer for claims. This does not affect your statutory rights.

#### 10.2 Cases not covered (Australia and New Zealand only)

In addition, the warranty also does not cover the following cases:

- Any damage from improper preparation before first use, such as weathering your product.
- Accidental or malicious damage by negligence or faults caused by a failure to provide routine maintenance.
- Accessories such as pegs and guy lines.
- Repairs carried out by repair agents that are not authorized by Dometic.
- Any loss or damage caused by a failure to follow the manufacturer's instructions for usage, installation, operation or maintenance.
- Damage/failure to operate caused as a result of improper installation or infestations of vermin, pests or insects.
- Perceived faults where the product is operating within the normal range of Dometic performance specifications and these performance specifications were made known to you prior to purchase.

### 11 Disposal



Place the packaging material in the appropriate recycling waste bins, wherever possible. Consult a local recycling center or specialist dealer for details about how to dispose of the product in accordance with the applicable disposal regulations.

### 12 Technical data

Width	2.6 m	3 m	3.5 m	4 m
Extension	1.8 m		2.3 m	
Net weight	20.3 kg	23.6 kg	26.8 kg	30 kg





**dometic.com**

---

**YOUR LOCAL  
DEALER**

**[dometic.com/dealer](https://dometic.com/dealer)**

**YOUR LOCAL  
SUPPORT**

**[dometic.com/contact](https://dometic.com/contact)**

**YOUR LOCAL  
SALES OFFICE**

**[dometic.com/sales-offices](https://dometic.com/sales-offices)**

---