

Living Appliances 10 litre 240v Water Heater

Model; DSZF15-LJ/10CB

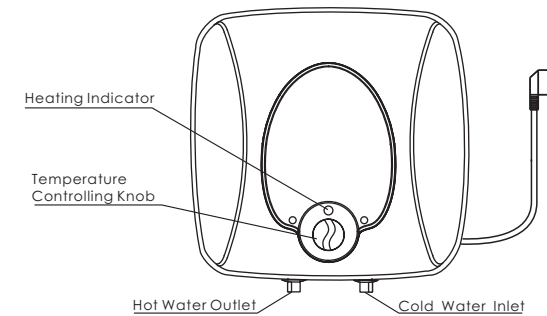

Technical Data

Rated Volume	10 litres		
Rated Voltage	220 – 240 volts	Rated Power	1500w
Rated Pressure	0,85Mpa	Rated Frequency	50Hz
Rated Water Temperature	75 degrees C	Heating Efficiency	>90%
Water Proof Rating	IPX4	Structure Mode	Hermetically closed type water storage style

Warning Notices

The following information **MUST** be observed during installation and use of this product.

Failure to follow these instructions could result in the failure of this product which in turn could result in serious personal injury and/or property damage.

- This product must be installed by a suitably qualified person.
- The maximum inlet pressure of this appliance is 0,85Mpa.
- If the mains electric supply cord is damaged, it must be replaced by the manufacturer, its service agent or a suitably qualified person in order to avoid the risk of a hazard occurring.
- A pressure relief valve shall be fitted to the cold-water inlet of this heater and must be operated on a regular basis in order to ensure that lime deposits do not build up and that it is not blocked
- CAUTION – in order to avoid a potential hazard due to inadvertent resetting of the thermal cut out of the water heater, this appliance must not be wired through an external switching device (such as a timer) or connected to a circuit that is subject to regular power outages controlled by the power supplier.
- The appliance is not to be used by persons (including children) with reduced physical, sensory or mental capabilities, or lack of experience and knowledge, unless they have been given supervision or instruction.
- Children must not play with this appliance nor be allowed to carry out cleaning or maintenance of this product without strict supervision.

- The appliance must be installed with a one-way pressure relief valve at the inlet side of the heater (blue inlet). If the pressure inside the tank rises above the stated rating (0,85Mpa), the relief valve will operate to relieve pressure and water will drain from the valve outlet and through the outlet pipe. This outlet pipe must always be installed so that water can drain vertically through it and must always be kept clear for this purpose and free from frost or other possible obstruction.
- If it is necessary to drain the water tank, firstly turn off the power to the water heater and also the water supply to the inlet side. Allow any heated water inside the tank to cool before draining. You can drain the tank by removing the fixed screw in the handle of the pressure relief valve (see diagram 1) and then by lifting the handle to the horizontal position (see diagram 2). This will allow the water to drain from the tank.

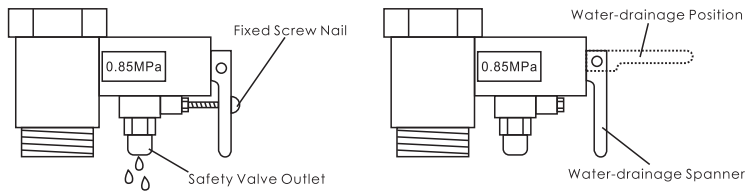

Diagram 1

Diagram 2

- **DANGER:** The operation of the thermal cut-out indicates a possibly dangerous situation. Do not reset the thermal cut-out until the water heater has been serviced by a qualified person.
- **DANGER:** Failure to operate the relief valve easing gear at least once every six months may result in the water heater exploding. Continuous leakage of water from the valve may indicate a problem with the water heater.
- If the water supply pressure exceeds the rated pressure, a pressure reducing valve is to be fitted in the installation.
- The appliance is intended to be permanently connected to the water mains and it is intended to be connected by a hose-set.

Mounting Instructions

- Installation of this product must be carried out by suitably qualified personnel and in accordance with any applicable local regulations or statutes.
- The water heater should be installed as close as practicably possible to the service points in order to minimise potential heat loss along the connecting pipework.
- In order to facilitate maintenance, it is recommended that you chose an installation location that allows a minimum of 50cm for ease of access to electrical parts.
- The water heater should be mounted on a substantial load bearing surface (preferred option is block work or concrete) as close as possible to the power socket (in to which it will be plugged) and also to the connection point to the plumbing system from which it will source its water.
- The water heater is supplied with a metal mounting bracket and (for use in concrete wall installations) two long mounting bolts. The use of the mounting bracket is recommended for all installations.

Packing List

<u>No.</u>	<u>Name</u>	<u>Unit (piece)</u>
1.	Storage hot water heater	1
2.	User Manual	1
3.	Installation bolts	2
4.	Mounting bracket	1
5.	Pressure Relief Valve	1

Disposal of this product

The symbol on this product or its packaging indicates that this product may not be treated as household waste. Instead it should be taken to an appropriate waste collection point for the recycling of electrical and electronic equipment. By ensuring this product is disposed of correctly you can help prevent potential negative impacts on the environment and human health which could otherwise be caused by the inappropriate waste handling of this product. For more detailed information about the recycling of this product please contact your local council, your household waste disposal agent or the retailer where you purchased this product.

- During the heating process, it is not unusual to see a slight drip from the pressure reducing valve (PRV) on the inlet side of the heater. Ensure that the drain tube of the PRV is securely fitted to the drain outlet of the PRV and that it is free from obstruction in order to allow any drips to drain.
- Remember – the PRV should be opened manually at least every 6 months to ensure that it is free from any possible buildup of lime deposits and that it is not blocked or obstructed in any way.

Maintenance

- All maintenance should be carried out by a suitably qualified person.
- If your heater fails to operate, first ensure that the water supply to the heater is turned on and that the tank of the water heater has been correctly filled.
- In order to completely empty the contents of the water heater tank, firstly ensure that the electricity supply is turned off and that the heater has been left for a sufficient period of time in order to allow any water inside the tank to cool to a safe operating temperature. Once this has been done, turn off the water supply to the heater on the inlet side, open the outlet tap and drain the water from the tank. You may then remove the pressure relief valve from the inlet side of the water heater and disconnect any fittings on the outlet side of the heater. Allow any surplus water to drain from the tank.

Trouble Shooting Guide

Symptom	Cause	Solution
Indicator light does not light up	<ol style="list-style-type: none"> 1. The power supply is not connected 2. The indicator light is damaged or has failed 3. The temperature cut out device has operated and requires re-setting 	Have a suitably qualified electrician check all electrical wiring and the indicator lamp
Water temperature fails to meet temperature setting	<ol style="list-style-type: none"> 1. The heating element is defective 2. The temperature controller has malfunctioned. 3. There is no power supply to the heater 	<ol style="list-style-type: none"> 1. Replace the heater element 2. Contact a suitably qualified professional to arrange repair 3. Check the power supply
No water flow from the warm/hot tap	<ol style="list-style-type: none"> 1. Main water supply is turned off 	<ol style="list-style-type: none"> 1. Ensure the water supply is turned on
Water leakage	<ol style="list-style-type: none"> 1. Leaking from plumbing connection 2. Leaking at the sealing gasket of the heating element 	<ol style="list-style-type: none"> 1. Tighten the appropriate plumbing connection 2. Tighten the element or replace the sealing gasket
Electrical mains supply tripped	<ol style="list-style-type: none"> 1. Heating element has short circuited 	<ol style="list-style-type: none"> 1. Replace the heating element of the heater

- Before deciding on the location of the mounting bracket ensure that a minimum clearance of 200mm at the bottom of the water heater has been allowed for (this is to facilitate both easy connection to the water inlet and outlet of the water heater and in order to perform maintenance operations).
- After deciding on the position of the mounting bracket and having securely affixed this to the wall (check diagrams below for guidance when installing on to a concrete wall), hang the water heater on to the mounting bracket as shown.

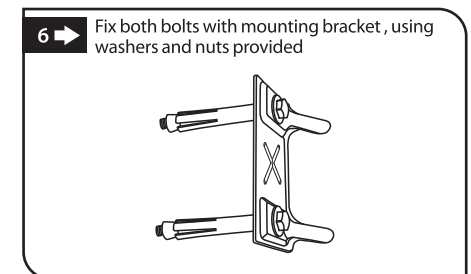
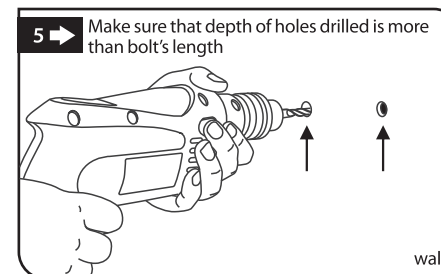
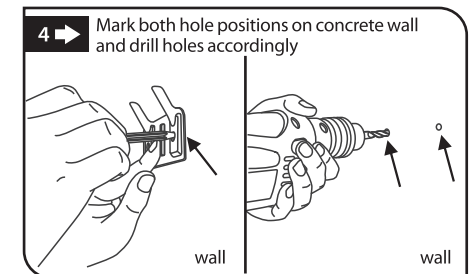
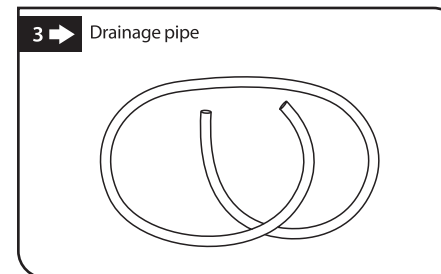
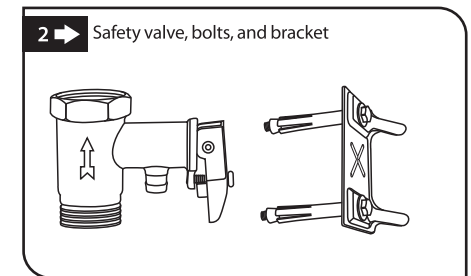
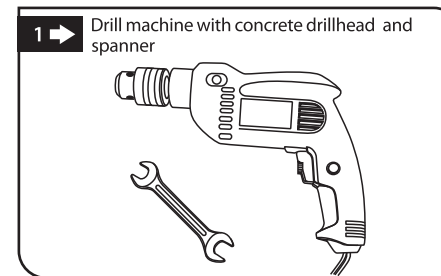
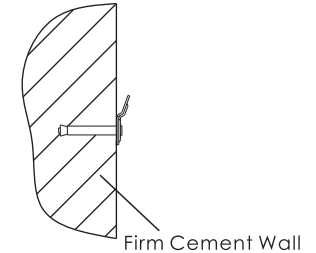
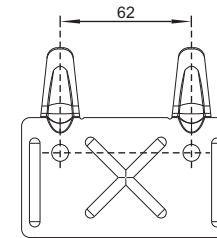

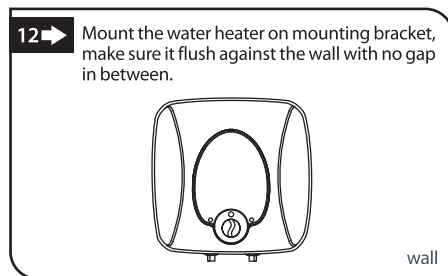
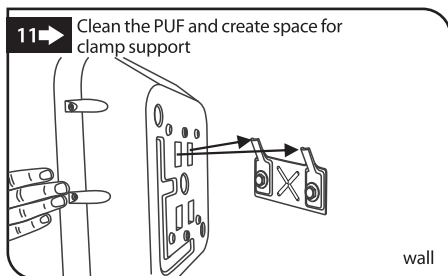
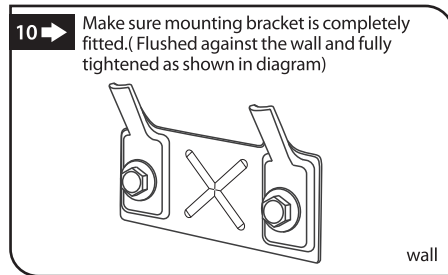
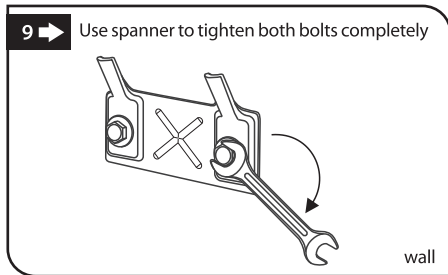
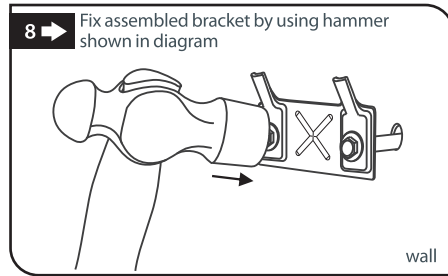
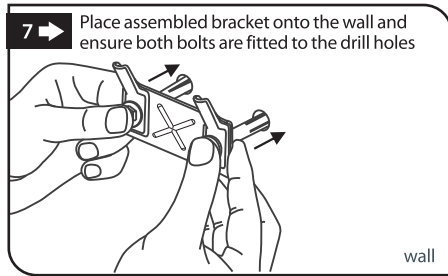

Pipe Connections

- Inlet and outlet fittings both have ½ inch BSP threads.
- Apply a leak protection/sealing tape such as PTFE to the inlet (blue) thread.
- Wind on to the inlet thread the pressure relief valve – be careful not to overtighten the valve, however ensure it is tight enough to ensure there are no leaks.
- Connect the cold-water supply pipe to the pressure relief valve – again the use of PTFE tape or similar is recommended to prevent leaks.
- Attach the clear drain hose (see figure 3) to the pressure relief valve outlet ensuring that the hose will remain in a vertical orientation to ensure that water will drain from the appliance in the event that the pressure relief valve is activated during use.
- Double check that all joints are leak free and that threads are not overtightened.
- Ensure that all pipes are clean and free of debris before connecting to outlet points (e.g taps and showers).

Temperature Operated Pressure Relief Valve (TPR)

Where this appliance is being installed in a mains water pressure setup, it is essential that a temperature operated pressure relief valve (TPR) is fitted to the outlet (hot water) side of the heater.

The specification of the TPR should be as follows;

Rating of TPR Valve: 850kPa, 99°C, 10kW.

Recommended TPR valve: Reliance Worldwide Corporation Model HTT55-1.

The TPR valve must be installed in accordance with its manufacturer's instructions.

Electrical Connections

- All electrical work must be carried out by a suitably qualified person.
- The heater is fitted with the appropriate plug for connection to a NZ socket/outlet. This socket must be earthed with the earth wire (yellow/green) connected to the appropriate pin.
- The supply socket shall be placed such that it is out of reach of anyone using a shower supplied by the heater.
- All wiring must comply with NZ Electrical Regulations and statutory requirements.

NOTE; All plumbing connections must be made prior to connecting the heater to the electrical supply. The heater tank should be filled and any surplus air expelled from the tank before turning on the electrical connection.

Wiring Diagram

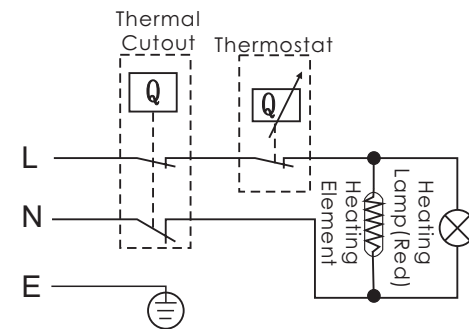

Operating Procedures

- Ensure that all connections are free of leaks and that the power supply lead is correctly connected before turning on the power supply to the water heater.
- Ensure that the heater tank is full of water before operating the heater as failure to do so may result in damage to the heating element.
- Once both items above have been checked, turn on the power supply to the heater and then adjust the temperature control. Turning the control knob in a clockwise direction increases the temperature to which the water is heated, turning the knob in an anti-clockwise direction reduces the temperature to which the water is heated.
- The heater will take a period of time in order to heat the water to the temperature selected by the control knob.