



GT2500ESi ELECTRIC START INVERTER GENERATOR

2500 WATT



Please ensure that you read this manual in full before using your machine and follow the maintenance and operation instructions carefully.

OPERATING INSTRUCTIONS

Contents

Introduction	3
Operator safety	4
Safety rules.....	4
Features and controls	9
Operating	14
Operating checklist.....	14
Starting the generating set.....	19
Connect to electrical devices.....	23
Stopping the generating set.....	25
Parallel operation.....	26
Maintenance	27
Maintenance schedule.....	27
Generating set maintenance	29
Engine maintenance.....	29
Trouble-shooting	33
Storage and transportation	34
Technical Specifications	35
Specification parameter table.....	35
Wiring diagram.....	36
Warranty	37

Introduction

Your new GT POWER Generator will more than satisfy your expectations. It has been manufactured under stringent quality standards to meet superior performance criteria. You will find your new tool easy and safe to operate, and, with proper care, it will give you many years of dependable service.



CAUTION: Carefully read through this entire Instruction Manual before using your new GT POWER Generator. Take special care to heed the Cautions and Warnings.

Your generator has many features that will make your job faster and easier. Safety, performance, and dependability have been given top priority in the development of this tool, making it easy to maintain and operate.

Environmental Protection

Recycle unwanted materials instead of disposing of them as waste. All tools, hoses and packaging should be sorted, taken to the local recycling centre and disposed of in an environmentally safe way.



Scope Of Product

This product is suited for home and camping, back-up power, rural and commercial applications.

Description Of Symbols

The rating plate on your tool may show symbols. These represent important information about the product or instructions on its use.



Wear hearing protection.
Wear eye protection.
Wear breathing protection.



Conforms to relevant standards for electromagnetic compatibility.

Specifications

	GT2500ESi
Rated Output:	2300W
Max. Output:	2500W
Rated Voltage	230V
Frequency:	50Hz
Phase:	Single
Engine Model:	165FED/P
Engine Style:	OHV, Air Cooled, 4-Stroke
Starting:	Hand recoil or electric starting
Fuel Tank Capacity:	4.5L
Insulation grade	F
Protection grade	IP23M
Oil Capacity:	0.5L
Noise Level	59dBA
Run Time:	<6 hours
AC Power Outlets:	2x 10A, 230V 1 x 8.3A (12V)
Dimensions:	485 x 340 x 510 mm
Weight:	21.5kg

I. Operator safety

1. Safety rules



Pay attention to this safety alert symbol. Obey all safety messages that followed by this symbol to avoid possible property damage. INJURY or DEATH.

Each safety message is preceded by a safety alert symbol and one of three words, DANGER, WARNING, or CAUTION.

DANGER

Indicates a hazardous situation which, if not strictly complied with, will result in substantial property damage, serious injury or DEATH.

WARNING

Indicates a hazardous situation which, if not strictly complied with, may result in property damage, serious injury or DEATH.

CAUTION

Indicates a hazardous situation which, if not strictly complied with, could result in property damage or injury.



WARNING

READ THIS MANUAL COMPLETELY BEFORE OPERATING.

DO NOT operate this generating set until you have read ALL safety, Operation, and maintenance instructions listed in this manual.

Failure to follow the instructions may result in property damage, INJURY or DEATH.

The warnings and precautions discussed in this manual cannot cover all possible conditions and situations that may occur. It must be understood by the operator that common sense and caution are factors which cannot be built into this product, but must be possessed by the operator.

WARNING

This generating set is intended for residential consumer use only.

Air cooled generating sets cannot be run full time.

No personal-modified any part of the generating set or any unsuitable usage is allowed.



⚠ DANGER

TOXIC FUMES

The exhaust of the engine contains carbon monoxide, an odorless, colorless, poison gas. Using engine indoors **CAN KILL YOU!**

NEVER use inside any building or any kind of enclosure, **EVEN IF** doors and windows are open.

Place the engine in a well-ventilated area and carefully consider wind and air currents when positioning the engine.



⚠ WARNING

KICKBACK

Rapid retraction of the starter cord will pull hand and arm towards the engine faster than you can let go.

Unintentional startup can result in entanglement, traumatic amputation or laceration. Broken bones, fractures, bruises or sprains.



⚠ WARNING

FIRE

Operation of this engine may create sparks that can start fires around flammable material.

This engine may not be equipped with a spark arresting muffler. If the engine will be used around flammable materials, or on land covered with materials such as agricultural crops, forest, brush, grass, or other similar items, then an approved spark arrester must be installed.

In some area, a spark arrester is required by law.

Please contact local fire agencies for laws or regulations relating to fire prevention requirements.



Flammable materials can catch fire when they come into contact with hot surfaces. Do not place flammable objects within 1.5 meters.



⚠ WARNING

HOT SURFACE

Engine and generator generate heat during operation, so touching hot surfaces may cause severe scalding.

Avoid contact with high temperature exhaust gas.

Do not touch the high temperature surface.

Do not touch the generator when it is running or just stopped.

⚠ WARNING

Lithium battery is maintenance free, if you have any question, please contact a local authorized dealer.



⚠ DANGER

FIRE OR EXPLOSION

Gasoline is highly flammable and extremely explosive.

Fire or explosion can cause severe burns or death.

Keep flammable items away while handling gasoline.

Fill fuel tank outdoors and in a well-ventilated area with the engine stopped.

Always wipe off spilled fuel and wait until the fuel has dried before starting the engine.

DO NOT operate the engine with known leaks in the fuel system.

Use proper fuel storage and handling procedures.

DO NOT store fuel or other flammable materials nearby.

Empty the fuel tank before storing or transporting this engine.

Keep fire extinguisher handy and be prepared if a fire starts.

⚠ WARNING

Before each use, carefully check the parts for looseness or damage, observe the oil or fuel for leaks, or other conditions that may affect normal operation. All damaged or defective parts shall be repaired or replaced without delay.

Be clear about the location of all controls and safety signs.

Ensure that all safety indicators are always in the correct positions and in the correct working conditions.

Please run the generator on a level surface.

It is forbidden to block the cooling channel with objects.

It is forbidden to expose the generator to excessive humidity or a large amount of dust.

It is forbidden for children or untrained persons to operate the generator.

It is forbidden to run the generator unattended, so you must turn off the generator before leaving.

Do not touch the generator when it is running or just stopped.

Keep a space of 0.9 m around the generator to ensure good cooling.

**⚠ DANGER****MOVING PARTS**

Moving parts can cause severe injury. Keep hands and feet away.

DO NOT operate engine with covers, shrouds, or guards removed.

DO NOT wear loose-fitting clothing, dangling drawstrings or items that could become caught. Tie up long hair and remove jewelry.

The moving parts may catch operator's hand, feet, hair or clothes that will cause traumatic amputation or broken bones, fracture.

NEVER place fingers, hands, or body near the engine when it is running.



⚠ DANGER

ELECTRIC SHOCK

This generating set produces powerful voltage and the electricity **CAN KILL YOU**.

This generating set must be properly connected to an appropriate ground to help prevent electric shock.

Failure to properly ground generating set can result in electrocution, especially if the generating set is equipped with a wheel kit.

Consult an electrician for local grounding requirements.

Installation should be performed by a certified electrician.

Improper Installation can result in electric shock and death.

To reduce the risk of electric shock. **DO NOT** use electrical cords that are worn, frayed, bare or otherwise damaged.

DO NOT touch bare wires or receptacles.

DO NOT operate generating set in wet weather. Keep the

generating set dry.

DO NOT handle generating set or electrical cords while standing in water, while barefoot, or while hands or feet are wet.

Keep children or pets away from the generating set.

DO NOT hook up any generating set to a building electrical system without the proper use and installation of a transfer switch installed by a qualified electrician.

When using generating set for backup power, notify utility company. Use approved transfer generating set to isolate generating set from electric utility.

Failure to isolate generating set from power utility can result in death or injury to electric utility workers due to backfeed of electrical energy.

II. Features and controls

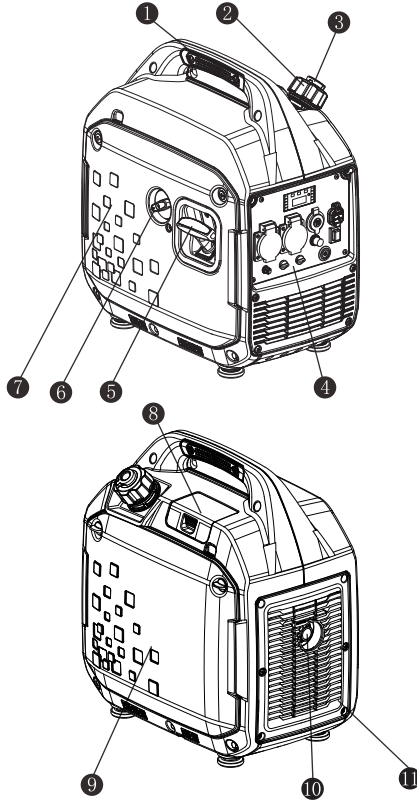

- | | |
|---|--------------------------------|
| ① Carrying handle | ⑦ Left cover |
| ② Fuel tank cap | ⑧ Spark plug maintenance cover |
| ③ Ventilation knob (If applicable) | ⑨ Right cover |
| ④ Control Panel | ⑩ Muffler |
| ⑤ Recoil starter | ⑪ Muffler blind window |
| ⑥ Transfer switch
(CHOKE&RUN&OFF&STOP) | |

Control Panel

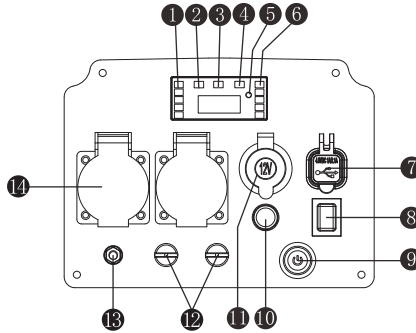

- | | |
|---------------------|-------------------------|
| ① Power indicator | ② Overload indicator |
| ③ Running indicator | ④ Oil alarm lamp |
| ⑤ Reset button | ⑥ Fuel display |
| ⑦ USB port | ⑧ Energy-saving switch |
| ⑨ push-button start | ⑩ Circuit breaker |
| ⑪ 12V DC | ⑫ Parallel kit terminal |
| ⑬ Ground terminal | ⑭ Output receptacle |

Overload indicator (red)

When the overload indicator is on, it indicates that the generating set is overload and then the AC protector works. It will stop the output of generating set to protect the electric equipment and the generating set itself. At this time, the running indicator (green) is off and the overload indicator (red) is on, but the engine is still in running state.

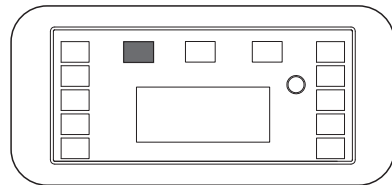

When the generating set has no output and the overload indicator is on, please take the following steps:

1. Lower the total power of the connected electric devices to the rated output range of generating set.
2. Check the air intake for impurities and check the

control parts for abnormal situation. Handle immediately if necessary.

3. Press the reset button.

Running indicator (green)

The running indicator lights up when generating set starts and has normal output.

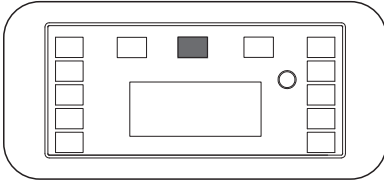

Reset button

The reset button is used to restore output if an overload occurs. To restore output, reduce the loads and press the reset button.

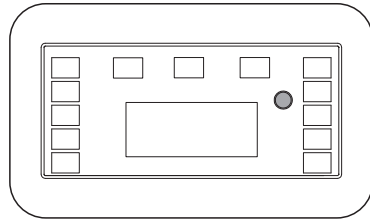

Oil alarm lamp (yellow)

When the oil level drops below the lower limit, the oil protection system will stop the engine automatically and oil alarming lamp will blink by pulling the recoil starter. The engine will not run until the oil has been filled to the proper level.

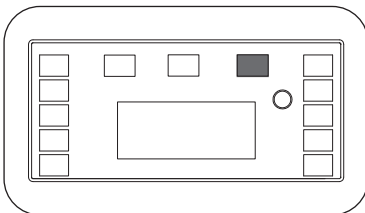

Energy-saving switch

When the energy-saving switch is in “ON” position, the energy saving equipment controls the engine rotate speed according to the connected loads. There will be good fuel consumption and low noise.

When the energy-saving switch is in “OFF” position, the engine will always run in rated rotate speed no matter it is connected to the loads or not.

Note: Please set the energy-saving switch to “OFF” position when connect to air compressor, sinking pump etc., because these equipments need large starting current.

Note: If engine flames out or fails to start, turn the combination switch to “RUN” position and then pull the recoil starter. If the oil alarming lamp lights up, it shows lack of oil. Please add appropriate oil and restart the engine.

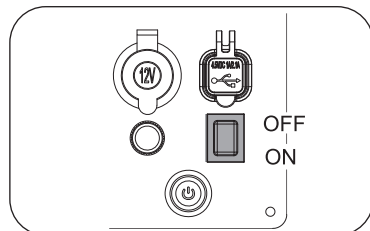

Grounding terminal

The grounding terminal is designed to prevent electric shock by connecting it to the grounding wire. The generating set must be properly grounded before operation.

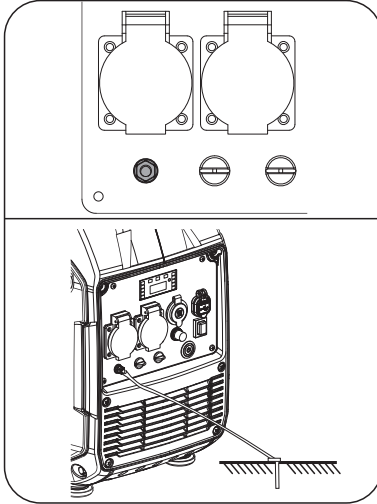

Note: If you do not plan to use the generator in the near future, please use this function, or drain the fuel inside the carburetor through the carburetor drain bolt.

Stop: The stop position of the generator.

Note: After the generating set is unloaded, please run for 3 minutes at no load to stabilize the temperature, then stop the generating set.

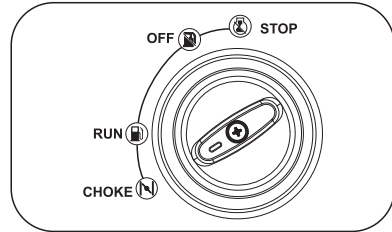

Transfer switch (CHOKE&RUN&OFF&STOP)

Note: One-button start and remote control start, no function of manually close for the choke.

Choke: Close the choke.

Note: Turn to choke position to start when engine is cold, and turn to Run position to start when engine is hot.

Run: The generating set operates normally.

OFF: Fuel off without stop. This position can run out of the remaining fuel and improve the reliability of the generating set.

Push-button start

(If applicable)

You can start the generator by pressing the button with your finger.

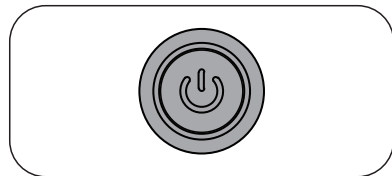

Parallel kit terminal

It is used for parallel operation with another inverter (parallel kit sold separately).

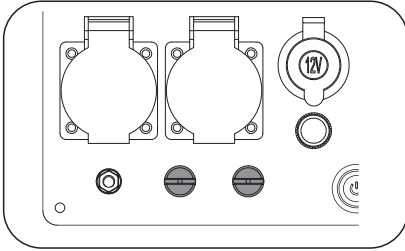

Ventilation knob

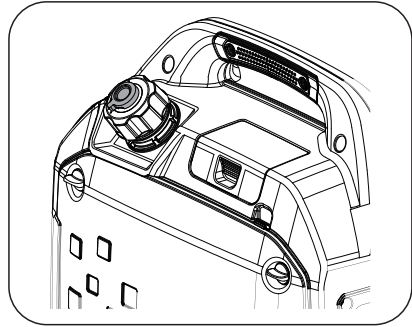

Fuel tank cap

Remove the fuel tank cap by rotating it anticlockwise.

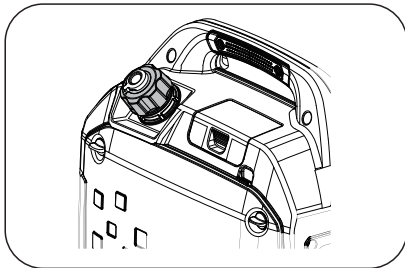

The fuel cap is equipped with a ventilation knob to prevent fuel leakage. During operation, the ventilation knob must be in the "ON" position for the generator to operate normally. When the generator will not be use for a long time or needs to be transported, turn the ventilation knob to the "OFF" position to prevent fuel leakage.

III. Operating

1. Operating checklist

1 Operating Location

Only use OUTSIDE and place the generating set in a well-ventilated area.

Only operate the generating set on a flat, level surface and in a clean, dry operating environment.

Allow two feet clearance on all side of the generating set while operating it outdoors.

Operate in specified area, if any problem on applicable occasion, please consult the authorized local dealers. In some areas, generating set must be registered with the local utility. Generating set used to construction sites may be subject to additional rules and regulations.



⚠ DANGER

TOXIC FUMES

The exhaust of the generating set contains carbon monoxide, Using engine indoors CAN KILL YOU!

NEVER use inside any building or any kind of enclosure, EVEN IF doors and windows are open.

Place the generating set in a well-ventilated and clean area. Note the wind direction

and air current when place the generating set.

High altitude

This generating set may require a high altitude carburetor kit to ensure correct operation at high altitudes. Consult the authorized local dealer for high altitude kit information if you always operate your engine at altitudes above 5, 000 feet (1,500 meters).

⚠ CAUTION

Even with carburetor modification, generating set horsepower will decrease about 3.5% for each 1,000 feet (300 meters) increase in altitude. The effect of altitude on horsepower will be greater than this if no carburetor modification is made.

⚠ CAUTION

Operation the engine at altitude below 5, 000 feet (1,500 meters) with modified carburetor may cause the generating set to overheat and result in serious engine damage. Please restore factory specifications of the carburetor at the dealer when using the engine in a low altitude area.

2 Operating Condition

Check for loose or damaged parts, signs of oil or fuel leaks, and any other condition that may affect proper operation.

Repair or replace all damaged or defective parts immediately.

⚠ WARNING

Failing to correct problem(s) before operation could result in property damage, serious injury or DEATH.

Clean the dirt or foreign objects on the surface around exhaust and air intake of generator.

DO NOT move or tip the generating set during operation.

Use generating set only for intended uses. If you have questions about intended use, ask your local dealer.

3 Engine oil check

Place the engine on a level surface with engine stopped. Check the engine oil level.

Remove the oil maintenance cover.

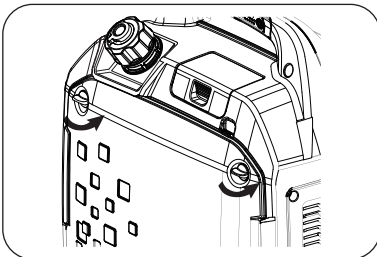

Remove the dipstick and wipe it clean.

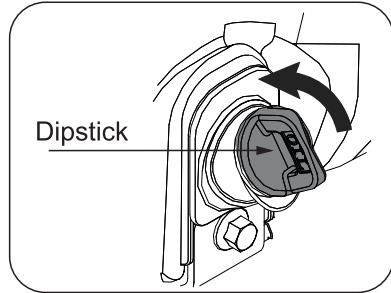

Reinstall dipstick into hole; rest on oil fill neck, DO NOT thread cap into hole.

Remove the dipstick again and check oil level. Level should be between the upper and lower limit.

Fill to the upper limit of the dipstick with the recommended oil if the oil level is too low.

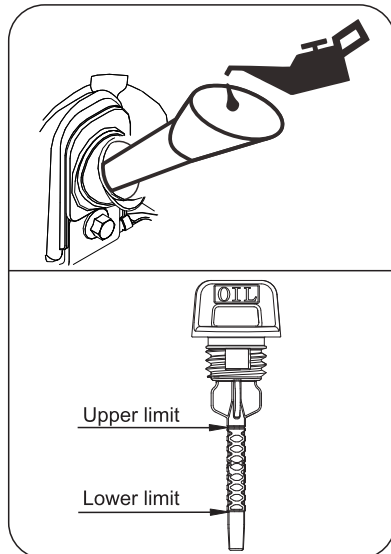

Reinstall and fully tighten the dipstick.

Refer to **add oil** instruction in **MAINTENANCE** section for more information.

Oil capacity(rated):

See Parameters

⚠ WARNING

Oil is a major factor affecting performance and service life. Use 4-stroke automotive detergent oil recommended in the **MAINTENANCE** section of this manual.

⚠ CAUTION

Operate generating set only on leveled surfaces. The engine is equipped with a low oil sensor (applicable types) that will automatic stop the engine when the oil level falls below the safe limit. To avoid the inconvenience of an unexpected shutdown. Fill to the upper limit and check the oil level regularly.

⚠ WARNING

This engine is not filled with oil before send out to the factory. Any attempt to crank or start the engine before it has been properly filled with the recommended type and amount of oil may result in engine damage and void your warranty.

4 Generating set fuel check

With the engine stopped, check the fuel level. Refill the fuel tank if necessary.

Use clean, fresh, regular unleaded gasoline.

DO NOT mix oil with gasoline.

Always wipe up any spilled fuel.

⚠ CAUTION

Pressure can build up in the fuel tank. Allow the generating set to cool for at least two minutes before removing fuel cap.

Loosen the fuel cap slowly to relieve any pressure in the tank.

Be sure not to fill above the upper limit mark. Always allow room for fuel expansion.

Fuel capacity (rated):

See parameters.



FIRE OR EXPLOSION

Gasoline is highly flammable and extremely explosive.

Keep flammable items away while handling gasoline.

Fill fuel tank outdoors and in a well-ventilated area with the generating set stopped.

Always wipe off spilled fuel and wait until the fuel has dried before starting the generating set.

DO NOT operate the generating set with known leaks in the fuel system. Regularly check if there is any leak on fuel system.

Use proper fuel storage and handling procedures. DO NOT store fuel or other flammable materials nearby.

Keep fire extinguisher handy and be prepared if a fire starts.



Do not fill the fuel tank above the upper limit. Over fill will result in engine die or damage the carbon canister (if equipped) and void your warranty.



To minimize gum deposits in your fuel system and to insure easy starting, do not use gasoline left over from the previous season.

NEVER use engine or carburetor cleaner products in the fuel tank or permanent damage may occur.

It is important to prevent gum deposits from forming in essential fuel system parts, Such as the carburetor, fuel filter, fuel hose or tank during storage. Also, experience indicates that alcohol-blended fuels (called gasohol, ethanol or methanol) can attract moisture, which leads to separation and formation of acids during storage.

Acidic fuel can damage the fuel system of the generating set while in storage. Be sure to review the instructions given in "Storage" section.

Gasoline/Alcohol blends: up to 10%alcohol, 90%unleaded gasoline by volume is approved as a fuel. Other gasoline/alcohol blends are not approved.

Effects of old, stale or contaminated fuel are not warrantable.

⚠ CAUTION

Allow the generating set to cool for at least two minutes before removing fuel cap when adding fuel.

Loosen the fuel cap slowly to relieve any pressure in the tank.

5 Battery connection (If applicable)

Remove the battery maintenance cover, connect the battery terminal to the motor terminal, and reinstall the maintenance cover.

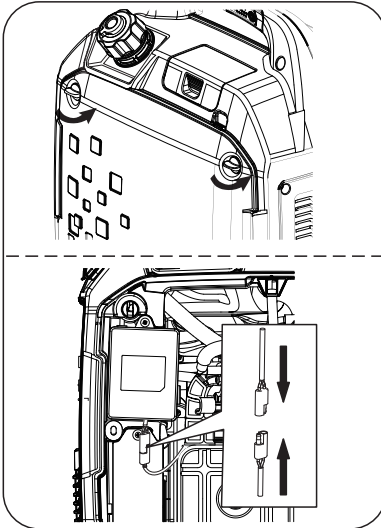

6 Electrical devices

Disconnect all electrical devices from the generating set and switch off the AC circuit breaker before start the engine. The generating set may be hard to start with electrical devices connected.

The power of connected electrical devices cannot exceed the generating set max power, specific power see parameter sheet for reference.

7 Generating set grounding

The generating set must be properly connected to an appropriate ground. It helps prevent electrical shock if a ground fault condition exists in the generating set or in connected electrical devices, especially when the unit is equipped with a wheel kit.

Proper grounding also helps dissipate static electricity, which often builds up in ungrounded devices.



⚠ DANGER

Electrical Shock

Failure to properly ground the generating set can result in electric shock.

A ground terminal has been provided on the generating set.

For remote grounding, connect of A ground terminal has been provided on the generating set. For remote grounding, a copper wire that is no small than (4mm²) should be used between the generator ground terminal and the ground.

The grounding requirements varies from different regions, so we strongly recommend your to consult a qualified dealer in your area. We strongly recommend that you consult with a qualified electrician for grounding requirements in your area.

2. Starting the generating set

1

Perform operating checklist and remove all loads.

2

Turn the ventilation knob of fuel cap to the “ON” position to ensure fuel flow.

Note: You don't need to follow this step, if your generator has no carbon cannister.

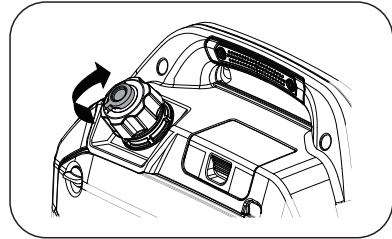

3 (Suitable for hand start)

Cold start

Turn the combination switch to “CHOKE” position to shut off the choke.

Warm start

Turn the combination switch to “RUN” position, if not started, please turn the combination switch to “CHOKE” position before restarting.

4

Turn the ECO switch to “ON” position. Please turn the ECO switch to “OFF” position when large starting current needed.

5

Manual start

WARNING

Check starter cord conditions before operating. Have it replaced immediately by local authorized dealer if cord is frayed.

1. When starting engine, grasp the recoil starter handle and pull slowly until resistance is felt. Then pull rapidly to avoid kickback. When pulling the recoil starter, firmly grasp the generator to avoid tumble of generator or personal injury caused by tumble.

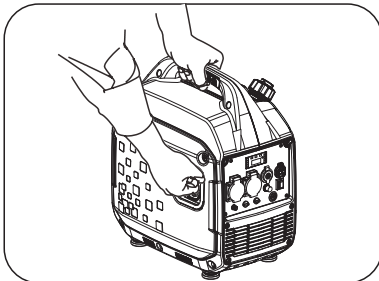

WARNING

KICKBACK

Rapid retraction of the starter cord will pull hand and arm towards the engine faster than you can let go.

Unintentional startup can result in entanglement, traumatic amputation or laceration. Broken bones, fractures, bruises or sprains could result.

2. Turn the Transfer switch to “RUN” position.

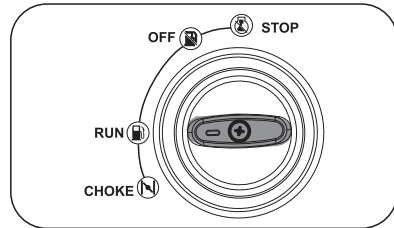

6 electric starting

(Model used)

Cold / hot engine start (electric start): Turn the combination switch to “Run” position.

Press the engine switch and release it after the engine starts.

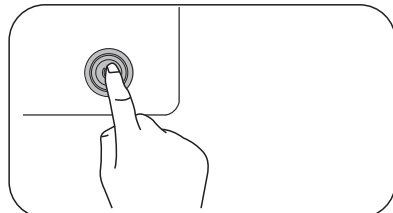

If it fails to start, release the switch. The unit will restart by itself. If it fails to start after repeated 5 times, please allow the generator to cool for 1 minute and start again.

Note: If electric start fails, you may try manual start.

⚠ CAUTION

Never continue to start the generator without removing the fault.

It's forbidden to start the generator after changing to another battery without authorization.

⚠ WARNING

If the generator cannot be started due to the long time storage or improper use, please follow the manual start steps to manually control the choke and start the generator. The generator will automatically charge the lithium battery after normal operation.

⚠ WARNING

If you try to start the generator for three times, and the generator still cannot start or shut down after start, please find the cause and troubleshoot.

If the generator equipped with oil alarm, the generator will not start if the oil level in the crankcase is lower than the lowest level.

During the break-in, please do a regular oil inspection, and please perform maintenance at the recommended interval. For details, please refer to the maintenance chapter.

⚠ WARNING

The engine shall not exceed 15 seconds for each continuous start. If it fails to start, please allow the generator to cool for 1 minute before next attempt to start. Failure to do so will damage the starter motor.

Wireless remote control

(If applicable)

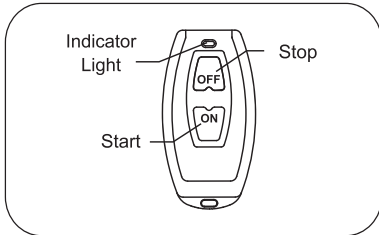

Operating

1. Turn on the remote control switch.
2. Press the START button and hold for more than 0.3s for startup.

NOTE: Sometimes the generator can take a few attempts to start in cold weather. If machine does not start in the first 10 seconds, wait for 30 seconds before attempting again.

If the motor turns a little then stops when you press the Start button, it may indicate a low battery. Charge the battery before operation or start by recoil start.

7

After completing the operations above, the generator can be connected to electrical devices.

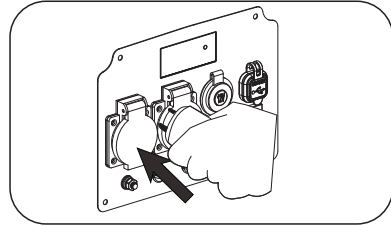

When electrical device requires a large starting current, please put the energy-saving switch in the "OFF" position; When the starting current required by electrical device is small, put the energy-saving switch in the "ON" position.

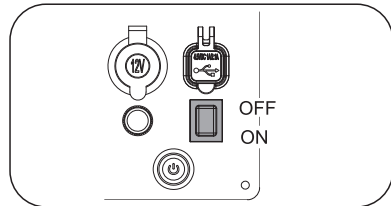

⚠ WARNING

It is prohibited to start or close the generating set when the output terminal of generating set is connected to an electric device and the electric device is in "ON" state.

3. Connect to electrical devices

1. Inspect power cord for damage before using. There is a hazard of electrical shock from crushing, cutting or heat damage.
2. Make sure that the generating set has been properly grounded. If the electric devices require grounding, the generating set must ground.
3. Make sure that the electric devices are in "OFF" position.
4. Allow the engine to stabilize and warm up for a few minutes after starting.
5. Connect and start the electric devices.
6. Turn off all electric devices and disconnect them from the generating set.
7. If the generating set supplies for several loads or electric devices, start the smallest one first and the largest one last.



If connected devices overheat, turn them off and disconnect them from generating set.



ELECTRICAL SHOCK

To reduce the risk of electrical shock, DO NOT use electrical cords that are worn, frayed, bare or otherwise damaged.

DO NOT touch bare wires or receptacles.

DO NOT handle generating set or electrical cords while standing in water, while barefoot, or while hands or feet are wet.

Loading capacity



DO NOT overload the generating set.

Exceeding the generating set's capacity can damage the generating set and/or electric devices connected to it.

You must make sure your generating set can supply enough rated (running) and (starting) watts for the electrical devices at the same time. Follow these simple steps to calculate the running and starting watts necessary for your purposes.

- a. Count the electrical devices you will power at the same time.
- b. The amount of power you need to run with the devices is the total rated (running) watts of these items.

c. Starting power is the power needed shortly when electric devices start. Since not all devices start at the same time, starting power can be estimated by the maximum power of all devices plus the total power counted in step b.

⚠ WARNING

It is necessary to equip with circuit protector or switch to isolate the generating set from the electric utility when the generating set is mainly used for backup. Failure to isolate the generating set from the power utility may result in injury or death to electric utility workers and damage to the generating set due to back feed of electrical energy.

Wattage Reference Chart

Electric equipment		Rate power(W)	Starting power(W)
Appliances	Tablet TV 27"	80	100
	Energy saving lamb	5-50	5-50
	Electric cooker	1000	1000
	Computer	250	250
	Electric fan	50	100
	Washing machine	250	500
	Refrigerator	50	300
	Air-conditioner	1600	3200
Electric tooling	Electric hammer	1000	1500
	Impact Hammer	3000	6000
	Water pump	2200	5000
	Electric welding machine	5000	7500
	Air compressor	5000	10000

4. Stopping the generating set

1

Remove the connectors of all electric equipment from the generating set panel.

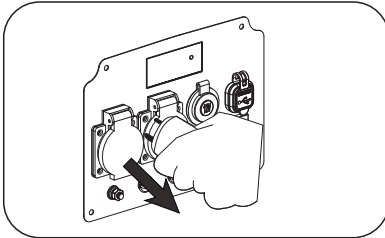

WARNING

NEVER stop the engine with electrical devices connected and running.

2

Turn the combination switch to the “stop” position, the generator stops operation.

Wireless remote shutdown (if applicable)

Press and hold the “OFF” button for at least 0.3 seconds to stop the generator. After the generator stops, turn the combination switch to the “stop” position.

Note: When the control distance is shortened or the indicator light is on but the remote control function is not available,

Wireless remote replace the battery. Contact your local dealer for more information.

One-button start-stop (if applicable)

Press the start-stop button to turn off the generator. After the generator shutdown, turn the combination switch to “stop” position.

WARNING

If the generator will not be used for a long time, please turn the combination switch to the “off” position. After the fuel in the carburetor oil cup to runs out and the generator automatically shuts down, turn the knob to the “stop” position. If the combination switch knob is not turned to the “stop” position, there is a risk of fuel leakage. And the battery will be undercharged after a long time placed, resulting in failure to start the generator.

3

After the generator stops and cools down, turn the fuel tank cap ventilation knob to “OFF” position.

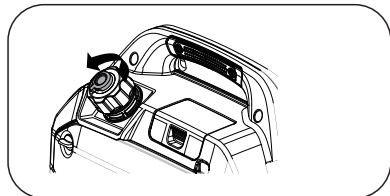

5. Parallel operation

(If applicable)

Make sure that the generating set is in a good running state before connecting it to other generating sets. The total power of electric devices should not exceed rated power of generating set.

When electric motor starts, the overload indicator (red) will light up and normally it will stop within 4 seconds. If it cannot stop, please consult your local dealer.

During parallel operation, energy-saving switches of generating sets should be in the same position.

1

Connect one generating set to other generating set(s) in parallel. Use the parallel kit to make the parallel connection (the parallel kit needs to be purchased separately).

2

Start the engine in proper order and make sure that the running indicator (green) is normal.

3

Connect the plug of electric devices to the AC receptacle of parallel kit.

4

Run the electric devices.

CAUTION

When overload too much, overload indicator (red) blinks continuously, and the generating set may be damaged. When overload a little, overload indicator (red) lights up continuously, it may shorten the service life of generating set.

When continuously operating the generating set, power cannot exceed the rated power of generating set.

The total power of electric devices cannot exceed the rated power of generating set. The manufacturers of electric devices or tools always list the rated power of similar models or serial number.

IV. Maintenance

It is the operator's responsibility to complete all scheduled maintenance in a timely manner. Correct any issue before operating the generating set. Always follow the inspection and maintenance recommendations and schedules in this manual.

⚠ WARNING

Improper maintenance or failure to correct a problem before operation can cause a malfunction and result in property damage, serious injury or DEATH.
Improper maintenance will void your warranty.



Accidental starts can cause Severe injury or death. Remove the spark plug cap and ground generating set before performing any service.

⚠ CAUTION

The filter element may contains PAHs, PAHs are harmful for your health. Please wear gloves for protection during air filter maintenance.

1. Maintenance schedule

Stop the generating set before serving, disconnect all electric devices and battery (If equipped), and cool down the generating set completely.

Serve the generating set in a clean, dry and flat area, so that no accident would happen during the serving. Please make the wheel in brake state to stop accidental movement of generating set.

Follow the service intervals indicated in the chart below. Service your generating set more frequently when operating in adverse conditions.

Contact your local authorized service dealer for your generating set or engine maintenance needs.

		Each time before use	The first month or 10 hours ^{note2}	Every three months or 50 hours ^{note2}	Every six months or 100 hours ^{note2}	Every year or 300 hours ^{note2}
Engine oil	Inspection	√				
	Replacement		√		√	
Air filter	Inspection	√				
	Cleaning			√ ^{note3}		
Spark plug	Inspection and adjustment				√	
	Replacement					√
Spark Extinguisher ^{note1}	Cleaning				√	
Idle speed	Inspection and adjustment					√ ^{note4}
Valve clearance	Inspection and adjustment					√ ^{note4}
Carbon canister ^{note1}	Inspection	Every two years ^{note4}				
Low permeability oil tube ^{note1}	Inspection	Every two years ^{note4}				
Oil tube	Inspection	Every two years ^{note4}				

NOTE :

Note1: Applicable types (If available).

Note2: Before each season and after then (whichever comes first).

Note3: Service more frequently under severe, dusty, dirty conditions.

Note4: To be performed by knowledgeable, experienced owners or the authorized dealer.

2. Generating set maintenance

Use a damp cloth to clean exterior surfaces of the generating set. Use a soft brush to clean the dirt and oil.

Use an air compressor (25 PSI) to clear dirt and debris from the generating set.

Inspect all air vents and cooling slots to ensure that they are clean and unobstructed.

⚠ WARNING

DO NOT use water to clean the generating set. Water can enter the generating set through the cooling slots and damage the generating set windings.

⚠ WARNING

It is forbidden to tamper with the generator in any of the above ways. Do not tamper with the inverter speed. The generator is set to the correct rated frequency and voltage before factory. Tampering with the factory settings of the inverter without authorization will void your product warranty.

3. Engine maintenance

Engine oil

⚠ WARNING

The engine is not filled with oil at the factory. Any operation before it has been properly filled with the recommended type and amount of oil may result in engine damage and void your warranty.

Only use four-stroke engine oil of SJ, SL or equivalent level which are in accordance with or higher than API standard.

Check the API label on oil bottle or other container, and make sure the "SJ, SL" or equivalent level letter is in the label.

SAE 10W-30 is recommended for general, all-temperature use. Other viscosities shown in the chart may be used when the average temperature in your area is within the indicated range.

Recommended Engine Oil Type

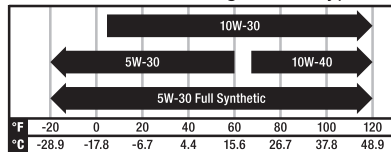

Ambient temperature

Oil capacity (rated):
See parameters

Add oil

- a. Place the engine on a level Surface.
- b. Remove the Right cover

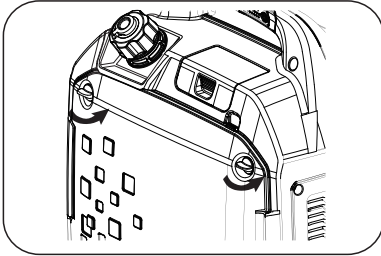

- c. Remove the dipstick and wipe it clean.

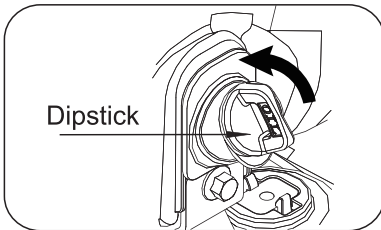

- d. Add recommended oil to the upper limit.

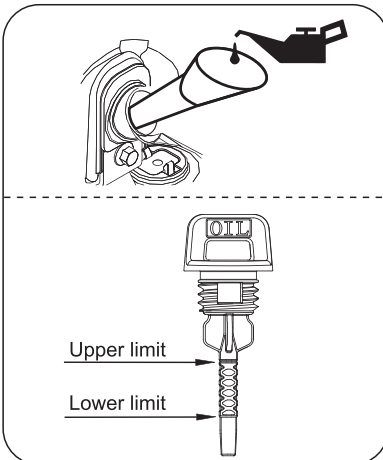

- e. Fully tighten the dipstick.

CAUTION

Oil level check

Insert the dipstick into filler port and stay at the filler neck. Do not screw the dipstick into the port, then remove the dipstick and check the oil level.

- f. Dispose of used oil at an approved waste management facility.

Change oil

CAUTION

Change oil when the engine is warm from operation. The oil temperature can reach up to 140°C in the warm state, and careful operation should be taken when changing the oil to prevent burns.

- a. Place the machine on a level surface which is 300mm higher than the ground.
- b. Remove the Right cover

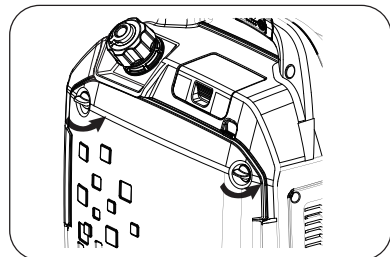

- c. Place the waste oil box on the ground.
- d. Remove the oil dipstick, and tilt the machine to pour the oil.

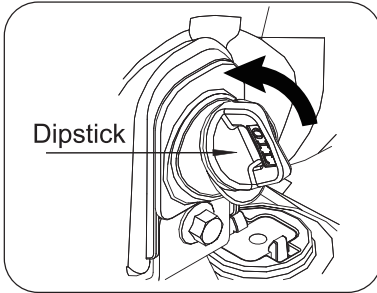

- e. Add recommended oil to the upper limit.

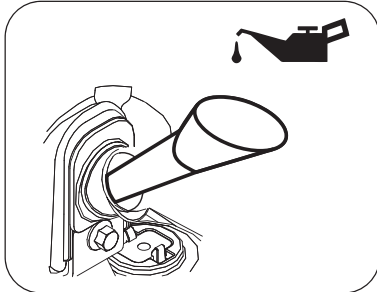

- f. Fully tighten the dipstick.
- g. Properly dispose of any used oil at an approved waste management facility.
- h. Reinstall the oil maintenance cover.

Air filter

- a. Remove the appearance cover.
- b. Loosen the filter fix clamp and remove the cover of the air filter.
- c. Remove the foam filter element.

- d. Wash in liquid detergent and warm water.
- e. Squeeze thoroughly dry in a clean cloth.
- f. Saturate in clean engine oil.
- g. Squeeze in a clean absorbent cloth to remove all excess oil.
- h. Assemble the filter element onto the filter unit
- i. Assemble the filter fix clamp.
- j. Reinstall the appearance cover.

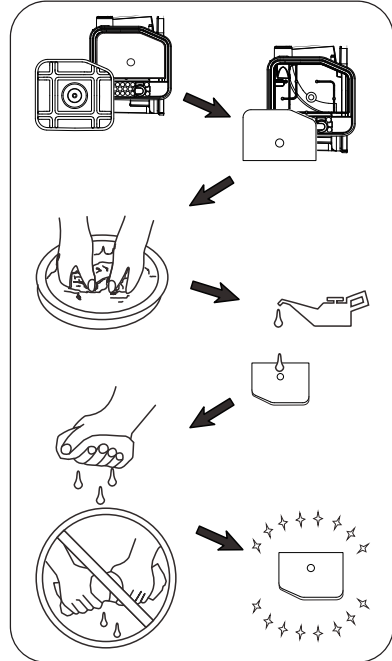

WARNING

DO NOT run the engine without the air filter, or serious danger can result.

Spark plug

- Clean any dirt from the spark plug cap and spark plug base.
- Remove the spark plug cap.
- Using socket wrench to loose and remove the spark plug.
- Inspect the spark plug and spark plug washer, if it was broken or worn, replace with a new one. Clean the spark plug with wire brush if reuse it.
- Check spark plug gap. Carefully bend side electrode to adjust the gap if necessary.

Spark plug gap:

0.6mm-0.8mm

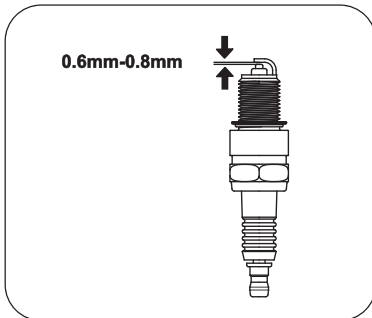

- Carefully thread the plug into the engine **by hand**.
- After the spark plug is seated, use spark plug wrench to tighten the plug.

Spark Plug Tighten Torque:

15-20 N.m

- Attach the spark cap to the plug and connect the spark plug wire to the plug.

WARNING

Only use recommended spark plug or equivalent. **DO NOT** use spark plugs that have improper heat range.

Spark Arrester

(Applicable types)

- Allow the generating set to cool completely before servicing the spark arrester.
- Remove the muffler blind window first.
- Remove the spark arrester screen.
- Carefully remove the carbon deposits from the spark arrester screen with a wire brush.
- Replace the spark arrester if it is damaged.
- Reinstall the spark arrester in the muffler and reinstall the muffler blind window.

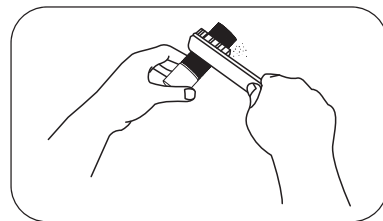

Clean carbon deposit

V. Trouble-shooting

Failure	Trouble	Solution
Generating set fails to start	Transfer switch is in "OFF" or "STOP" position.	When engine is cold, Transfer switch to "CHOKE", and follow starting procedure to start the generating set. When engine is hot, Transfer switch to "RUN", and follow starting procedure to start the generating set,
	Lack of fuel.	Fill fuel tank per instructions in this manual.
	Lack of engine oil.	Check oil level. This engine is equipped with a low oil sensor. The engine cannot be started unless the oil level is above the prescribed lower limit.
	No ignition.	Remove the spark plug cap. Clean any dirt around the plug base, and then remove the spark plug. Install the spark plug in the plug cap. Turn the Transfer switch to "RUN" position. Grounding the electrode to any engine ground, pull the recoil starter to see if sparks jump across the gap. If there is no spark, replace the plug. Reinstall the plug and start engine according to instructions in this manual. Consult Customer Service if necessary.
	Spark plug is splashed by fuel	Remove the spark plug and wipe the fuel.
	The generating set flames out after running for a certain time.	Turn the ventilation knob on the fuel tank cap to "ON" position; Check the fuel and oil level. Add them if necessary.
	Battery undercharge (electric start)	Charge the battery by starting the generator manually (at least 30 minutes). After closing the choke manually, start the generator according to the manual startup steps.
Generating set has no output	Breaker trip	Reset circuit breakers.
	Inadequate cord sets or extension cords.	Check cord sets or extension cords capabilities in section controls; cable size in this manual. Consult Customer Service if necessary.

VI. Storage and transportation

Storage

The generating set should be started at least once every 2 weeks and allowed to run for at least 20 minutes. Follow the instructions below for longer term storage if the generating set will be out of service for 2 months or more.



⚠ DANGER

Fire or explosion

Gasoline is highly flammable and extremely explosive.

Empty the fuel tank and shut off fuel valve before storing or transporting this generating set.

1. Allow the generating set to cool completely before storage.
2. Clean the generating set according to instructions in Maintenance section.
3. Drain all fuel completely from the fuel tank, fuel hose and carburetor to prevent gum from forming.
4. Turn the Transfer switch in “STOP” position to cut off the fuel.
5. Remove the oil drain plug to drain out the oil (See “Engine oil” section).
6. Remove the spark plug and pour about 15 ml of fresh oil into the cylinder. Pull the recoil starter slightly to distribute the oil and lubricate the cylinder. And then

attach the spark plug.

7. Store the unit in a clean, dry area out of direct sunlight.

8. please disconnect the battery.

Transportation

When generator transportation or short term storage, the generator should be in the normal operating position and fixed vertically to prevent fuel leakage. The combination switch should be in the “stop” position and knob of the fuel cap should be turned to the “OFF” position.

⚠ WARNING

When transporting:

Do not overfill the tank. Do not operate the generating set while it is on vehicle. Take the generating set off the vehicle and use it in a well-ventilated place. Avoid a place exposed to direct sunlight when putting the generating set on a vehicle. If the generating set is left in an enclosed vehicle for many hours, high temperature inside the vehicle could cause fuel to vaporize resulting in a possible explosion. Do not drive on a rough road for an extended period with the generating set on board. If you must transport the generating set on a rough road, drain the fuel from the generating set beforehand.

VII. Technical Specifications

1. Specification parameter table

Parameter	GT2500ESi
Engine model	165FED/P
Style	OHV, Air Cooled, 4-Stroke
Ignition system	CDI
Start style	Hand recoil or electric starting
Oil capacity(L)	0.5
Frequency(Hz)	50
Voltage(V)	230
Rated power(W)	2300
Maximum power(W)	2500
Insulation grade	F
Protection grade	IP23M
Fuel capacity(L)	4.5
Operating temperature(°C)	-10~40
Noise level (dBA)	59
Running time	<6 hours
Dimensions (mm)	485x340x510
Power Outlets	2
Net weight(kg)	21.5

Note: The generating set with different specification and configurations may have different parameters and may change at any time without notice.

2. Wiring diagram

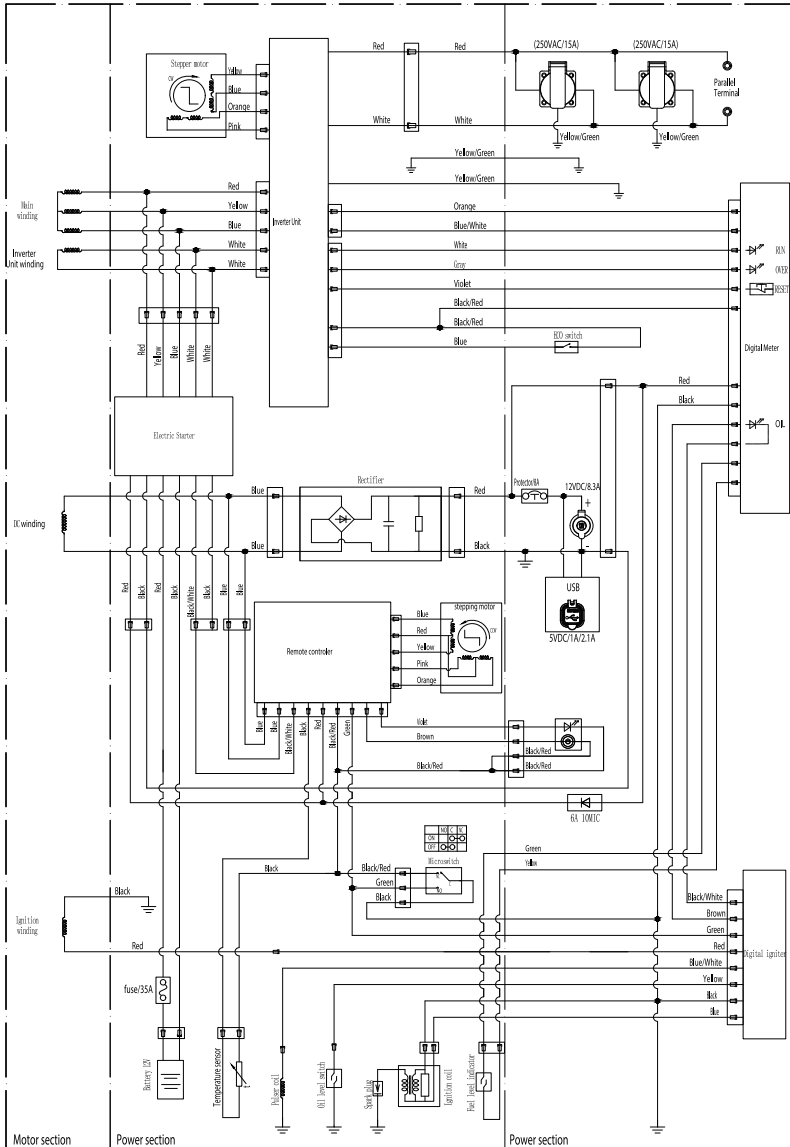

NOTE: Because of the difference of generator, the wiring diagram is only for reference.

Warranty

As part of an on-going commitment to excellence in product support, Euroquip offers a comprehensive product warranty program.

Warranty period for:

GT2500ESi

Commercial/Domestic Use: 3 Years (36 months)

Purchased from a New Zealand Euroquip Dealer after 31/03/2023

Warranty covers failure caused by manufacturing and material defects in new purchased product only, during the warranty period specified. The warranty period begins when the product is purchased by the end user. Warranty is not transferrable and is only claimable by the original purchaser.

Warranty does not cover parts that are subject to wear and tear from usage and/or damage which results from neglect of periodic maintenance. Evidence must be provided that the product has been maintained and serviced suitably for a claim to be considered under warranty. Batteries supplied with your product are warrantied against defect for 3 months and does not include lack of charge due to non-use. Consumable items such as, but not limited to, oils, coolants, filter, spark plugs and batteries shall be the responsibility of the owner.

Failure caused by incorrect operation of the product, lack of proper care and maintenance of the product, external damage, external circumstances such as product deterioration due to environment, contaminated fuel, modifications to the product, attempted repair/ service by a party other than an Approved Service Agent, is not covered under warranty.

Warranty does not cover pre delivery service and adjustment, or failure that may occur as a result of lack of/ incorrect pre delivery service and adjustment. Warranty does not cover any incidental, indirect or consequential loss, damage, personal injury, or expense that may result from any defect, failure, malfunction, or misuse of a product.

Should any issue be found to be a combination of a warranty failure and a non-warranty issue such as incorrect charging techniques, the repair cost component to rectify and repair the non-warranty failure is the **customers'** full responsibility.

The decision that an issue with a product qualifies as a warranty claim is made at the sole jurisdiction of Euroquip.

No costs incurred will be considered under warranty if repairs are carried out by any party other than a Euroquip Approved Service Agent, unless with prior consent in writing from Euroquip.

It is the full responsibility of the purchaser to deliver the product under warranty to the nearest relevant service agent or product reseller. Warranty does not cover call outs, mileage and freight costs.

If a product is repaired under warranty, parts and labour required for the repair will be supplied at no charge. All defective parts replaced under warranty become property of Euroquip. Warranty assessment and repair will be scheduled and executed according to the normal work flow at the service location and depending on the availability of suitable replacement parts.

This warranty policy is an additional benefit and does not supersede the legal rights of any customer, reseller or service agent.



Congratulations on your new GT POWER product. We are proud to have you as our customer and will strive to provide you with the best service and reliability in the industry. This product is backed by our extensive warranty and service network. To locate your nearest distributor or service agency visit www.euroquip.co.nz or email us at customerservice@euroquip.co.nz.