



Installation & operating instructions Isotherm Refrigerator/freezer CR 200 & CR 200 Stainless Steel-INOX



Indel Webasto Marine USA, Inc.
3400 Gateway Drive
Unit 107
Pompano Beach, FL 33069
Tel +1 954 984 8448, +1 800 422 9711
Fax +1 954 979 2533
E-mail: info@indelmarineusa.com
www.indelwebastomarineusa.com

Contents

1 Introduction

- 1.1 General
- 1.2 Safety and precautions
- 1.3 Environmental markings

2 Installation instructions

- 2.1 Ventilation
- 2.2 Electrical connections
- 2.3 Wire dimensions
- 2.4 Door panel

3 Operation

- 3.1 Temperature setting
- 3.2 Defrosting

4 Maintenance

- 4.1 Battery voltage sensor

5 Technical data

6 Trouble shooting

7 Installation dimension drawings

1 Introduction

1.1 General

Isotherm refrigerators are specially designed to operate in tough marine environments. They are fitted with a fully hermetic, leak-free compressor, they offer the lowest possible power consumption and noise level. All models are simple to install. They can withstand an angle of heel up to 30°, for a short time. To ensure that your Isotherm fridge operates as efficiently as possible, please follow these general guidelines:

- Unnecessary opening of the fridge door will increase power consumption.
- Good ventilation of the compressor and condenser unit will reduce power consumption.
- The electrical system should be in good condition. Inspect batteries and charging levels regularly. Always use a separate starter battery for the engine. Follow carefully the guidelines regarding electrical able areas and fuse placements.
- Keep the inside of the fridge and freezer clean and dry. Remove any water from condensation that may have collected in the plastic baskets.
- Keep the door slightly open to air the refrigerator and freezer when leaving the boat for any length of time. (Fig. 1 and 2)

1.2 Safety and precautions

For your own and others safety, read this first.



Danger! Only connect the device to a 110 - 230 Volt power outlet installed according to regulations, being accordingly fused.

When connected to mains power, ensure that the power supply is equipped with an earth safety automatic switch, a "ground fault circuit interrupter".



Danger! Never touch bare electrical wiring connected to the AC power supply.

Do not use the device if the connector cables show visible damage.

Never connect battery charger direct to the refrigeration system.

A battery charger **must** be connected to the battery, never direct to the refrigeration system.

Danger! In addition to acid, a newly-charged battery contains explosive gas.

Never cover the ventilation openings for the compressor unit.

Refrigerant may never be let out in the air.

1.3 Environmental markings



The symbol  on the product, or on the documents accompanying the product, indicates that this product may not be treated as household waste. Instead it shall be handed over to the applicable collection point for recycling of electrical and electronic equipment. Disposal must be carried out in accordance with local environmental regulations for waste disposal.

For more detailed information about treatment, recovery and recycling of this product, please contact your local city office, your household waste disposal service or the shop where you purchased the product.

2 Installation instructions

Many boats have a space which is intended for a fridge. The Isotherm Cruise fridge has been designed to suit the general dimensions normally used for this purpose.

The compressor should normally stand upright in the boat, but will operate at an angle of heel up to 30° and for short periods even more. The compressor on CR200 is attached by its rear side.

The refrigerator/freezer unit has a three side mounting flange to fasten the unit in place. It must also be standing on its feet.

See installation dimensions on fig. 10.

Avoid mounting close to a heat source, like gas ovens and heaters. Also avoid a position allowing direct sunshine on the refrigeration/freezer unit.

The mounting position should be dry and protected from splashing water.

2.1 Ventilation

It is very important that the compressor/condenser unit is well ventilated and that cold air can enter at the bottom, pass behind the fridge and warm air can leave at the top in the area where it is mounted. The natural flow of air from below and upwards behind the fridge can be increased by arranging ventilation openings at the rear.

Make sure there is a free area of 23 - 28 sq.in. below and behind the refrigerator/freezer to allow ventilation air to pass behind from below. See fig 5.

2.2 Electrical connections/wiring for power supply

CR200 is available in two versions, one is equipped with a Danfoss 12-24 VDC electronic unit and the other is equipped with a AC-DC electronic unit. It is important that following points are considered:

DC (12 or 24 volt)

The electronic unit must always be connected direct to the battery poles. Connect the positive/plus to + and the negative/minus to - on the battery. Without proper positive/negative connections, the electronic unit will not work - it is protected against reverse battery connection.

For protection of the installation, a fuse must be mounted in the positive cable as close to the battery as possible.

A 15A fuse for a 12V power supply and a 7.5A fuse for a 24 volt circuit are recommended. If a breaker box connection is used, it should be rated to a minimum of 20A.

Avoid extra junctions in the power supply system to prevent voltage drop from affecting the battery protection setting.

The light is connected to battery power on the electronic unit and the bulb must be selected 12 or 24 volt. Both types are included in the delivery.

See wiring diagram fig. 8

AC (100-240 volt)

The live and neutral wires must be connected to the terminals marked **L** and **N** on the electronic unit. Nominal voltages from 100 to 240 VAC 50/60 Hz. Upper safety cut out limit is 270 VAC and lower limit is 80 VAC. Earth connection is to be placed on the compressor foot near the electronic unit. There is a hole drilled in the foot for this purpose, use a 5/32" screw and nut and a ring cable shoe on the wire.

Connection of mains power plug must fulfil valid electrical safety regulations and properly fused with 4A. Wire gauge, AWG18.

General AC/DC

Both AC and DC power supply can be connected to the electronic unit at the same time. AC will be preferred power supply source if that is the case. If the AC power supply is disconnected, a time delay of 1 minute will be activated before the compressor continues on DC power supply. If AC power supply is established there will be no delay in compressor operation, when power supply is shifting from DC to AC. The light power supply is connected to A and C. The output voltage on A and C is always regulated to 12 VDC. A 12 VDC bulb must be used for both 12 and 24 VDC power supply systems.

See wiring diagram fig. 9

2.3 Wire gauge selection chart 12 & 24 Volt

AWG	Max cable length in ft 12 volt	Max cable length in ft 24 volt
12	8	16
10	15	30
8	26	52

2.4 Door panel

The front panels on the doors can be replaced or additional standard front panels in white, teak, mahogany or cherry can be mounted on top of the standard panel.

Use a screwdriver or a knife as a lever and pull off the lower door profile. Unscrew the three screws holding the door lock.

Mount the extra panel on top of the existing one, fasten the door lock again and push in the lower door profile.

See fig. 5 and 6.

3 Operation

3.1 Temperature setting

The refrigerator/freezer unit is fitted with a manually operated thermostat. The thermostat control knob is placed inside the refrigerator compartment to the left.

This is turned clockwise to reduce temperature and anti-clockwise to both increase temperature and activate the on-off switch at the end position, 0-position. A certain spring resistance is recognized at the off position.

It is advisable to start with the thermostat in a medium position, **do not set the thermostat in the coldest position.** Remember that the thermostat settings are effected by variations in ambient temperature, the quantity of stored food, its position and how often the doors are opened.

If the ambient temperature is very high the compressor might work continuously causing the occasional formation of frost. If this occurs the thermostat knob should be turned to a lower number = warmer setting, to allow the compressor to cycle on and off.

If sufficient temperature can not be reached with thermostat/ compressor still cycling, it is a sign of improper ventilation on the rear side of the refrigerator/freezer.

The unit has just one thermostat, the freezer will automatically get the correct freezing temperature corresponding to the refrigeration temperature selected.

When the refrigerator/freezer is switched on after it has been out of use, the freezer compartment will be cold rather quick but it will take several hours until the refrigeration temperature is reached. To reduce humidity and the consequent increase of frost, never place liquids in unsealed containers in the refrigerator.

3.2 Defrosting

Defrosting shall be made when the frost layer is more than 1/8" thick. Set the thermostat in OFF position. Store the foodstuff and the liquid as cold as possible during the defrosting process. Do not use sharp metal tools to remove frost or ice. Do not re-start until the refrigerator/freezer is completely defrosted, cleaned and dried. Empty and clean also the plastic tray in the lower part of the compartments. The refrigeration compartment has a condense water drainage to the rear of the cabinet. Outside is a container mounted, where the condense water is automatically evaporated.

4 Maintenance

The Isotherm refrigeration systems have a fully hermetic closed cooling system and do not require any maintenance or refilling of refrigerant.

The compressor is of domestic type and has a very high efficiency and an outstanding life-time. The refrigerator/freezer shall be left in the boat during the winter. (If the temperature is below freezing point, the compressor may not start). The maintenance is reduced to periodically, not less than a year, cleaning of the condenser from dust. Use a soft brush and no sharp tools. Keep the cabinet inside clean. Use lukewarm water and a mild detergent for cleaning the inside. Put the doors, during not in operation periods, in their slightly open ventilation position. Release the catch on the door for this purpose with a coin or a small screwdriver (fig. 1 and 2) (not valid for Stainless steel version, "INOX"). Take out the bulb from the internal light to avoid power consumption or switch off a main switch if there is one installed connected to the refrigerator/freezer power supply. (Fig 3 and 4)

To prevent ice and frost build-up on the freezer door seal, this is warmed up by means of a internal warming system. It is not electrical connected.

4.1 Battery voltage sensor

To protect the batteries from becoming completely discharged, a battery voltage sensor switches off the compressor automatically at the following levels:

System Voltage	Cut-out	Cut-in
12 V	9.6 V (10.4 V)	10.9 V (11.7 V)
24 V	21.3 V (22.8 V)	22.7 V (24.2 V)

If the bridge between C and P is cut off, the values within the () are valid.

5 Technical data

Voltage:	DC type 12/24 VDC AC/DC type 100-240VAC - 12/24VDC
Current consumption:	~ 6 A on 12V (when the compressor is running)
Average current consumption:	2.3 - 4.0 A on 12V (depending on ambient temperature 70 - 95°F)
Current consumption in "off"-pos.:	7 mA on 12 V
Humidity:	Max 90%
Ambient temperature:	Max 110°F
Compressor:	Danfoss BD50F
Refrigerant:	R134a (filled amount written on type sticker inside the fridge compartment)
Fuse:	12 volt - 15 A, 24 volt - 7.5 A
Battery protection:	Cut-out at 9.6 volt (21.3), cut-in at 10.9 volt (22.7)



Isotherm refrigerators and freezers fulfills EMC directives, CE-marked

6 Fault finding chart

Fault	Possible cause	Action
Fridge not cold. Compressor will not start.	No power supply. Battery in poor condition. Faulty thermostat. Faulty electronic unit.	Check that power is present at terminal box. check fuse. Internal light works? Check all terminal connections and cables. Inspect battery charging system. Check thermostat. Bridge T-C, if compressor starts, thermostat is faulty, replace. If compressor does not start, probably electronic unit is faulty. Exchange electronic unit.
Compressor makes only short start attempts.	Bad power supply, too low voltage or a voltage drop at start attempts. Discharged batteries.	Check cables and connections, possible corrosion, clean. Charge batteries, run the engine or connect battery charger. Voltage shall be above 11.0 volt at start attempts.
Compressor runs but no refrigeration generated.	Loss of refrigerant. Leakage in pipes or evaporator. Pipes blocked.	Mount service nipple on the compressor (refrigerators). Leak test, repair possible leak, evacuate and re-fill refrigerant. (All this to be made by refrigeration specialist)
Compressor runs long time but not generating enough cold.	Bad ventilation. Condenser too warm. Fan not working. Too much frost on evaporator. Door not closing well. Condenser blocked by dust.	Improve ventilation for compressor. Replace fan. Defrost. Check door position and door seal. Clean condenser.
Fuse blows.	Wrong fuse size. Faulty electronic unit.	Check fuse 15A/12V or 7.5A-24V. Replace electronic.

Figures

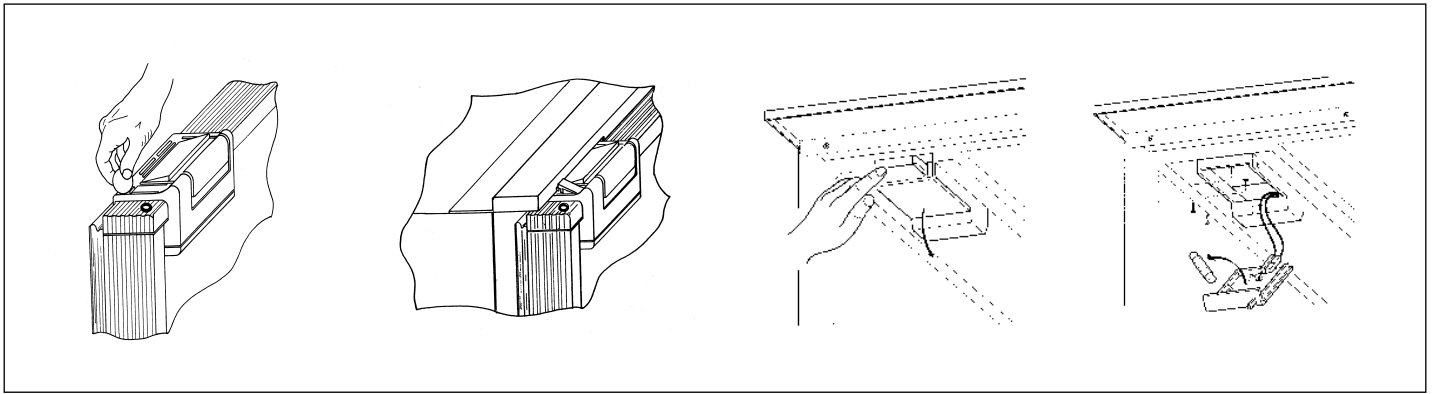
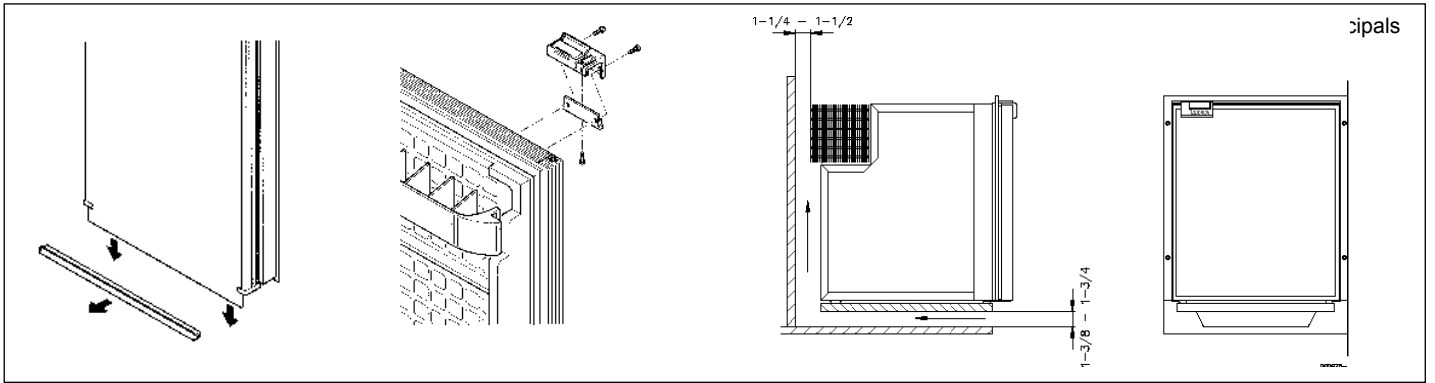

Fig. 1

Fig. 2

Fig. 3

Fig. 4



cipals

Fig. 5

Fig. 6

Fig. 7

Wiring diagram for CR 200 - 12/24 VDC

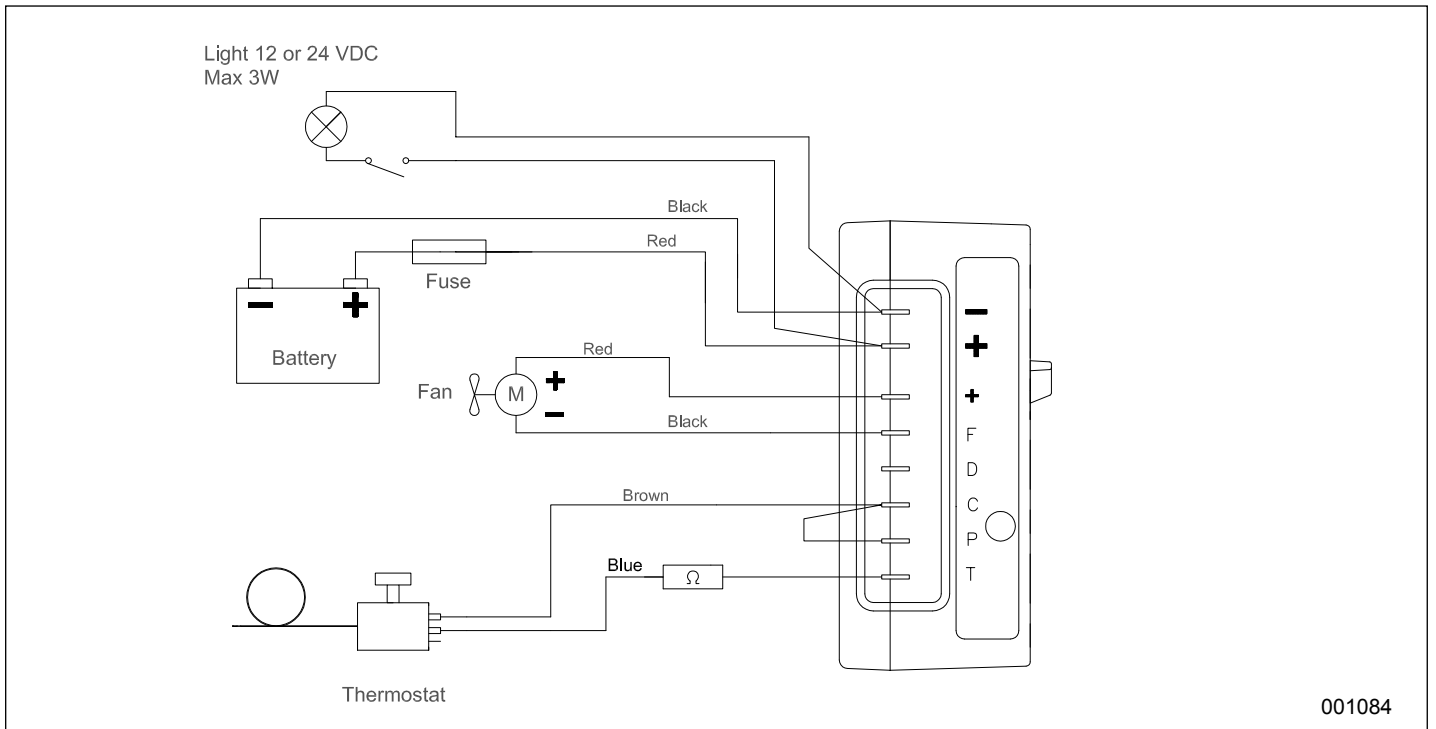

001084

Fig. 8

Wiring diagram for CR 200 AC/DC

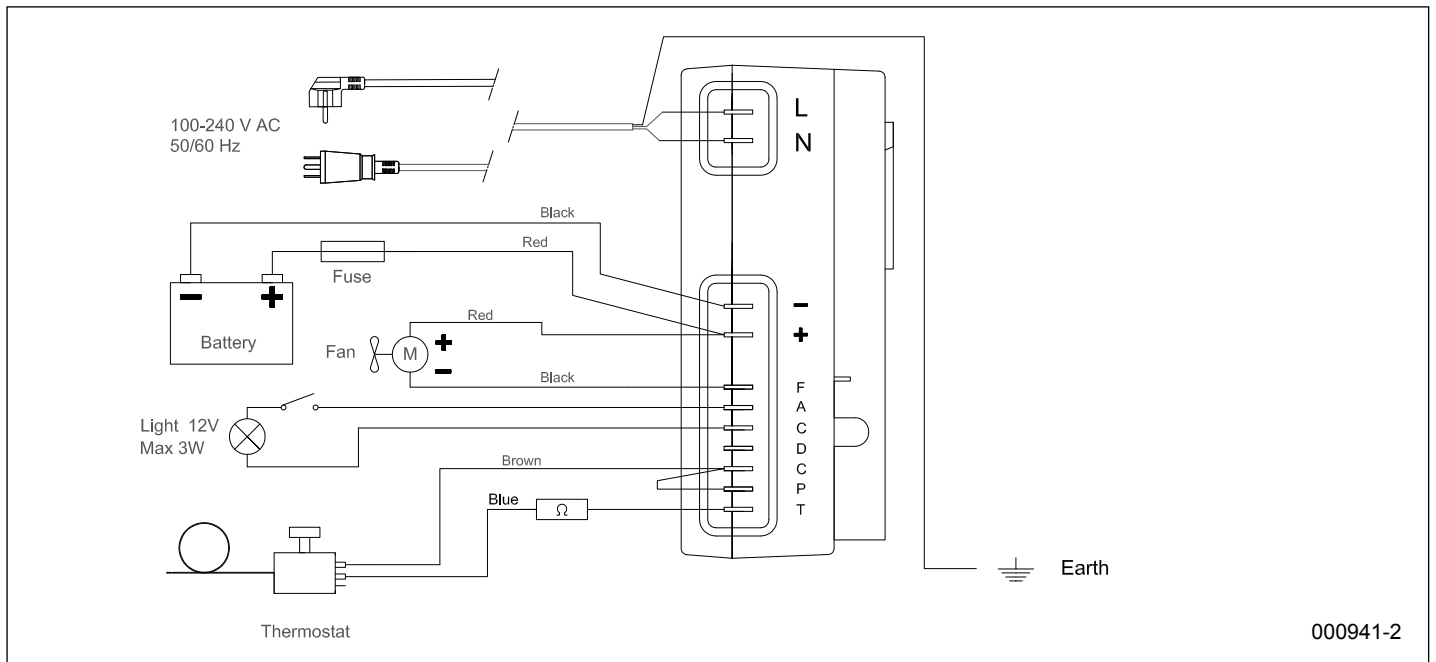

000941-2

Fig. 9

7 Installation dimensions CR 200 & CR 200 INOX

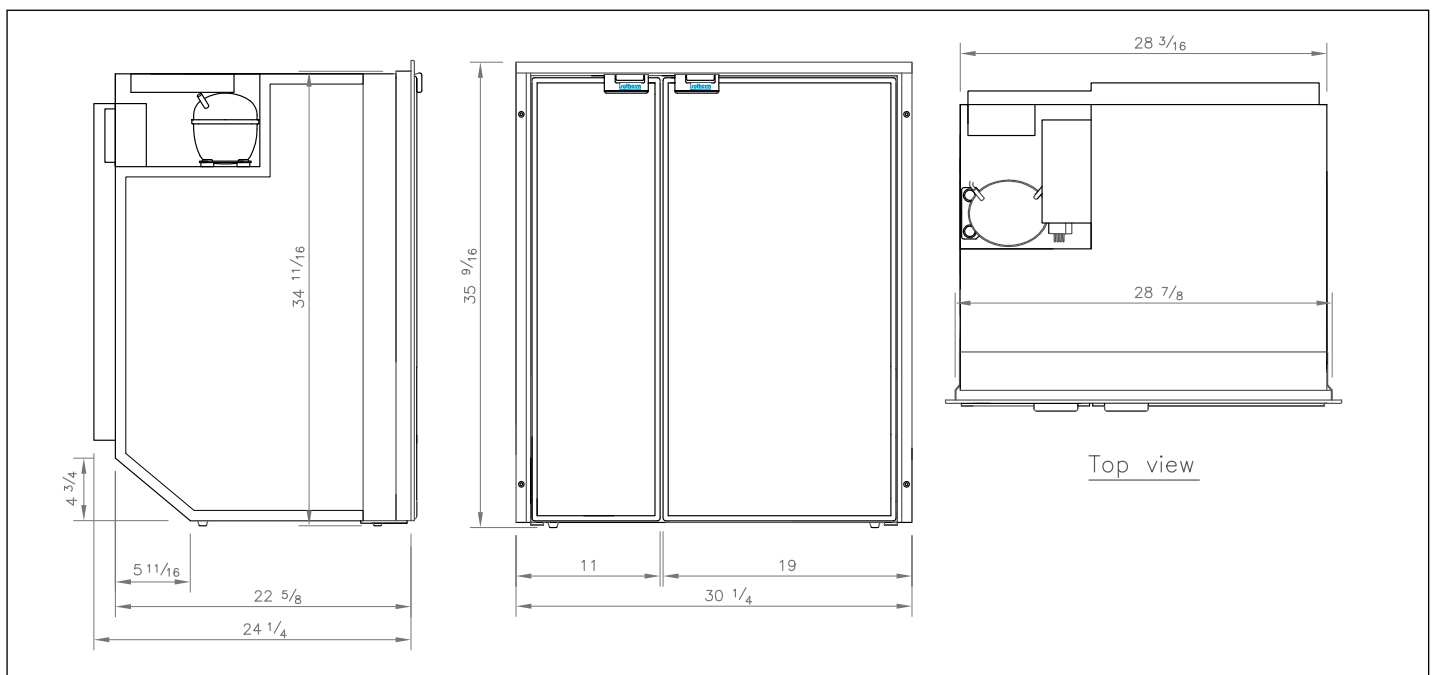

Fig. 10