

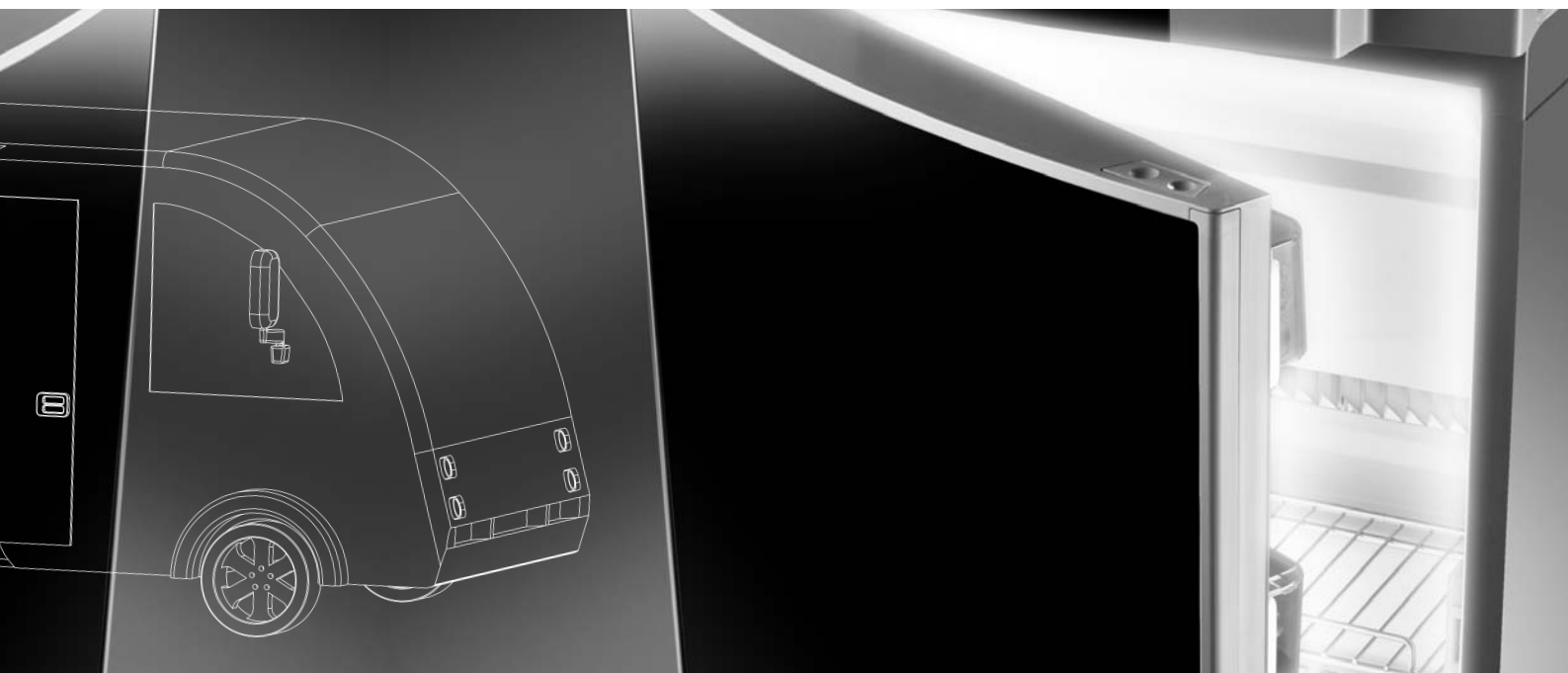

# Installation instructions

## Absorption Refrigerator for Recreation Vehicles

RM 8400 RM 8401 RM 8405 RM 8500 RM 8501 RM 8505 RM 8550 RM 8551 RM 8555  
RMS 8400 RMS 8401 RMS 8405 RMS 8460 RMS 8461 RMS 8465 RMS 8500 RMS 8501  
RMS 8505 RMS 8550 RMS 8551 RMS 8555 RML 8550 RML 8551 RML 8555 RMSL 8500  
RMSL 8501 RMSL 8505



**AUS / NZ**

MBA 05/2012

**N 1**

Type C40 / 110  
289 0318 - 09

 **Dometic**  
GROUP

## Table of contents

0.0	Unpacking and transport .....	3
1.0	General .....	4
1.1	Introduction .....	4
1.2	Guide to these operating instructions .....	4
1.3	Copyright protection .....	4
1.4	Explanation of symbols used in this manual .....	4
1.5	Warranty .....	5
1.6	Limitation of liability .....	5
1.7	Environmental notices .....	5
2.0	Safety instructions .....	6
2.1	Application according to regulations .....	6
2.2	User's responsibility .....	6
2.3	Working upon and checking the refrigerator .....	6
2.4	Operating the refrigerator with gas .....	6
3.0	Description of model .....	7
3.1	Model identification .....	7
3.2	Refrigerator rating plate .....	7
3.3	Technical data .....	7
4.0	Installation instructions .....	10
4.1	Installation .....	10
4.1.1	Side installation .....	10
4.1.2	Side installation with floor-roof ventilation .....	11
4.1.3	Rear installation .....	11
4.1.4	Draught-proof installation .....	12
4.2	Ventilation and air extraction .....	13
4.3	Installing the ventilation system .....	13
4.3.1	Ventilation systems for small refrigerators (120 ltr. cap. or less) .....	13
4.3.2	Ventilation systems for large refrigerators (larger than 120 ltr. cap.) .....	14
4.3.3	Installing LS 100/LS 200 or LS 300 .....	15
4.3.4	Installing roof exhaust R500 .....	16
4.4	Exhaust gas duct and installing the fume flue .....	16
4.5	Installation recess .....	17
4.5.1	Installation in the recess .....	17
4.6	Securing the refrigerator .....	18
4.7	Inserting of the decor panel .....	18
4.8	Gas installation .....	20
4.9	Electrical installation .....	21
4.9.1	Mains connection .....	21
4.9.2	Battery connection .....	21
4.9.3	Terminal strip .....	22
4.9.4	D+ and solar connection (only for AES models) .....	24
4.9.5	Wiring diagrams .....	25



**WARNING!**

**DO NOT USE A FLAME TO  
CHECK FOR GAS**



## 0.0 Unpacking and transport

### Lifting / carrying the refrigerator

**CAUTION!**

Never use for lifting or carrying other parts of the refrigerator (i.e. cooling unit, gas pipe, frontpanel) !

The refrigerator will be damaged !

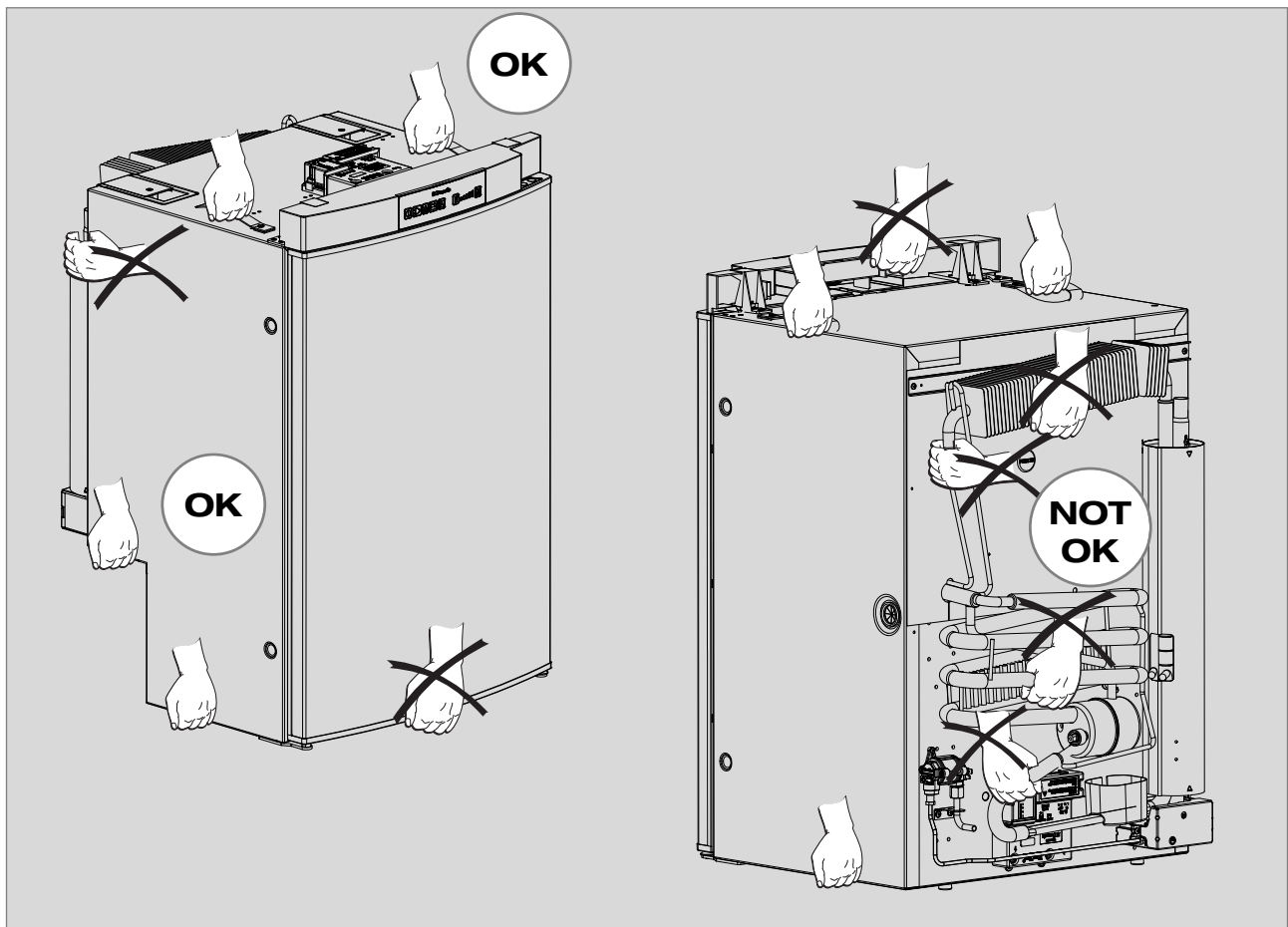

## 1.0 General

### 1.1 Introduction

On installation of the appliance, the technical and administrative regulations of the country in which the vehicle will first be used must be adhered to. Otherwise the refrigerator must be installed as described in these instructions.

### 1.2 Guide to these installation instructions

**Before you start installing the refrigerator, please read the installation instructions carefully.**

These instructions provide you with the necessary guidance for the proper installation of your refrigerator. **Observe in particular the safety instructions.** Observation of the instructions and handling recommendations is important for dealing with the refrigerator safely and for protecting you from injury and the refrigerator from damage. You must understand what you have read before you carry out a task.

**Keep these instructions in a safe place so they may be referred to at any time.**

### 1.3 Copyright protection

The information, texts and illustrations in these instructions are copyright protected and are subject to industrial property rights. No part of these instructions may be reproduced, copied or utilised in any other way without written authorisation by Dometic GmbH, Siegen.

### 1.4 Explanation of symbols used in this manual

#### Warning notices

Warning notices are identified by symbols. A supplementary text gives you an explanation of the degree of danger.

**Observe these warning notices rigorously. You will thus protect yourself and other people from injury, and the appliance from damage.**



**DANGER!**

**DANGER** indicates an imminent hazardous situation which, if not avoided, could result in death or serious injury.



**WARNING!**

**WARNING** indicates a potentially hazardous situation which, if not avoided, could result in death or serious injury.



**CAUTION!**

**CAUTION** indicates a potentially hazardous situation which, if not avoided, may result in minor or moderate injury.

**CAUTION!**

**CAUTION** (used without the safety alert symbol) indicates a potentially hazardous situation which, if not avoided, may result in damage to the appliance.

## Information



**INFORMATION** gives you supplementary and useful guidance when dealing with your refrigerator.

## Environmental Tips



**ENVIRONMENTAL TIPS** gives you useful guidance for saving energy and disposal of the appliance.

## 1.5 Warranty

Warranty arrangements are in accordance with the normal conditions applicable for the country concerned. For warranty or other maintenance, please contact our customer services department. Any damage due to improper use is not covered by the warranty. The warranty does not cover any modifications to the appliance or the use of **non-original Dometic** parts. The warranty does not apply if the installation and operating instructions are not adhered to and no liability shall be entertained.



**Deviations from these installation instructions without prior notification of Dometic result in Dometic's warranty obligations becoming void!**

## 1.6 Limitation of liability

All information and guidance in these operating instructions were prepared after taking into consideration the applicable standards and regulations as well as the current state of the art. **Dometic** reserves the right to make changes at any time which are deemed to be in the interest of improving the product and safety.

**Dometic** will assume no liability for damage in the case of :

- non-observation of the operating instructions
- application not in accordance with the regulations or provisions
- use of non-original spare parts
- modifications and interferences to the appliance
- effect of environmental influences, such as
  - temperature fluctuations
  - humidity

## 1.7 Environmental notices



Refrigerators manufactured by Dometic GmbH are free of CFC/HCFC and HFC. Ammonia (a natural compound of hydrogen and nitrogen) is used in the cooling unit as a coolant. Non-ozone-hazardous cyclopentane is used as a propellant for manufacturing PU foam insulation.

### Disposal

In order to ensure that the recyclable packaging materials are re-used, they should be sent to the customary local collection system.

## 2.0 Safety instructions

### 2.1 Application according to regulations

This appliance is designed for storage of food and storage of frozen food and making ice. The refrigerators outlined herein have been design certified for installation in a mobile home or recreational vehicle.

The refrigerator is to be used solely for storing foodstuffs.

#### CAUTION!

The refrigerator must not be exposed to rain.

### 2.2 User's responsibility

Anyone operating the refrigerator must be familiar with the safe handling and understand the advice in the operating instructions (part no. 289 0317-09).

### 2.3 Working upon and checking the refrigerator



#### WARNING!

Work on gas equipment, exhaust system and electrical facilities must be carried out by authorised personnel only. Substantial damage to property and/or injury to persons can arise through unprofessional procedures.



#### DANGER!



Never use an unshielded flame to check gas bearing parts and pipes for leakage!

There is a danger of fire or explosion..



#### WARNING!

Never open the absorber cooling unit! It is under high pressure.

There is a danger of injury!

### 2.4 Operating the refrigerator with gas

It is imperative that the operating pressure corresponds to the data specified on the rating plate of the appliance. Compare the operating pressure of the rating plate with the data specified on the pressure reducing valve of the liquid gas cylinder.

### 3.0 Description of model

#### 3.1 Model identification

Example :

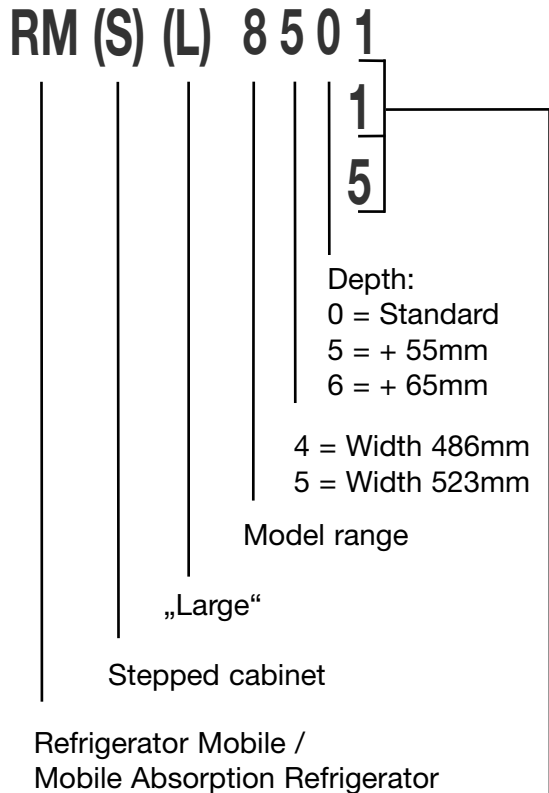

0  
 manual energy selection + manual ignition  
**(battery igniter)**

1  
 manual energy selection, automatic ignition  
**(MES)**

5  
 automatic and manual energy selection,  
 automatic ignition **(AES)**

#### 3.2 Refrigerator rating plate

The rating plate is to be found on the inside of the refrigerator. It contains all important details of the refrigerator. You can read off from this the model identification, the product number and the serial number. You will need these details whenever you contact the customer service centre or when ordering spare parts.

Example :

Dometic			
TYPE	C 40/110	CLIMATE CLASS	ST SAFETY CLASS
MOD. NO.	RMS 8400 <b>1</b>	PROD. NO.	00999002844 <b>2</b> MLC 00 SER. NO. 09990000 <b>3</b>
BRUTTOINHALT TOTAL CAP.	80 l	VERDAMPFERFACH FREEZER COMP.	8 l
VOLUME BRUT	85 l	VOLUME COMPT BT	0 l
NUTZINHALT USEFUL CAP.	77 l		
VOLUME NET	82 l		
~ 230 - 240 V	125 W	LPG	Qn: 0,252 kW (HS)
12 V	120 W		ñ: 18,3 g/h
		<b>5</b>	I3+ 28-30/37 I3B/P 28-30 mbar I3P 37
CE 0063 BL3214	G30, G31		p = 30/37 mbar
ABSORBER	NH <sub>3</sub> = 226 g	Na <sub>2</sub> CO <sub>3</sub> = 12,15 g	p max = 35 bar
			APPROVAL NO. N20462 ACN 004 947 488
		MADE IN GERMANY	00085394886

Fig. 1

- 1** Model number
- 2** Product number
- 3** Serial number
- 4** Electrical rating details
- 5** Gas pressure

### 3.3 Technical data

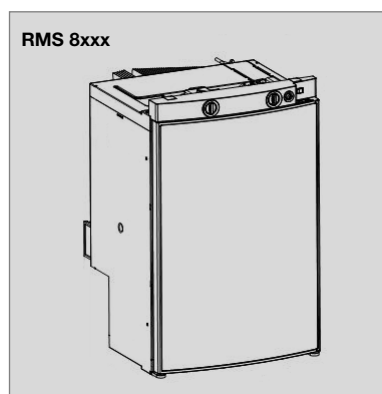

Fig. 2

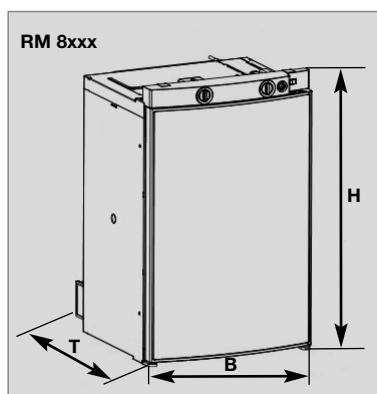

Fig. 3



Fig. 4

#### Models with curved door

Model	Dimensions H x W x D (mm) Depth incl. door	Gross capacity		Rating details mains/battery	Consumption * electricity/gas over 24hrs	Net weight	Ignition	
		with freezer compartment	without				Piezo	Automat
RMS 8400	821x486x568	80 / 8 lit.	85 lit.	125 W / 120 W	ca.2,5 KWh / 270 g	25 kg	•	
RMS 8401	821x486x568	80 / 8 lit.	85 lit.	125 W / 120 W	ca.2,5 KWh / 270 g	25 kg		•
RMS 8405	821x486x568	80 / 8 lit.	85 lit.	125 W / 120 W	ca.2,5 KWh / 270 g	25 kg		•
RM 8400	821x486x568	90 / 8 lit.	95 lit.	135 W / 130 W	ca.2,4 KWh / 270 g	27 kg	•	
RM 8401	821x486x568	90 / 8 lit.	95 lit.	135 W / 130 W	ca.2,4 KWh / 270 g	27 kg		•
RM 8405	821x486x568	90 / 8 lit.	95 lit.	135 W / 130 W	ca.2,4 KWh / 270 g	27 kg		•
RMS 8460	821x486x633	90 / 11 lit.	96 lit.	125 W / 120 W	ca.2,5 KWh / 270 g	26 kg	•	
RMS 8461	821x486x633	90 / 11 lit.	96 lit.	125 W / 120 W	ca.2,5 KWh / 270 g	26 kg		•
RMS 8465	821x486x633	90 / 11 lit.	96 lit.	125 W / 120 W	ca.2,5 KWh / 270 g	26 kg		•
RMS 8500	821x523x568	90 / 9 lit.	96 lit.	125 W / 120 W	ca.2,5 KWh / 270 g	26 kg	•	
RMS 8501	821x523x568	90 / 9 lit.	96 lit.	125 W / 120 W	ca.2,5 KWh / 270 g	26 kg		•
RMS 8505	821x523x568	90 / 9 lit.	96 lit.	125 W / 120 W	ca.2,5 KWh / 270 g	26 kg		•
RMS 8550	821x523x623	103 / 12 lit.	110 lit.	125 W / 120 W	ca.2,6 KWh / 270 g	27 kg	•	
RMS 8551	821x523x623	103 / 12 lit.	110 lit.	125 W / 120 W	ca.2,6 KWh / 270 g	27 kg		•
RMS 8555	821x523x623	103 / 12 lit.	110 lit.	125 W / 120 W	ca.2,6 KWh / 270 g	27 kg		•
RM 8500	821x523x568	100 / 9 lit.	106 lit.	135 W / 130 W	ca.2,4 KWh / 270 g	28 kg	•	
RM 8501	821x523x568	100 / 9 lit.	106 lit.	135 W / 130 W	ca.2,4 KWh / 270 g	28 kg		•
RM 8505	821x523x568	100 / 9 lit.	106 lit.	135 W / 130 W	ca.2,4 KWh / 270 g	28 kg		•
RM 8550	821x523x623	115 / 12 lit.	122 lit.	135 W / 130 W	ca.2,6 KWh / 270 g	30 kg	•	
RM 8551	821x523x623	115 / 12 lit.	122 lit.	135 W / 130 W	ca.2,6 KWh / 270 g	30 kg		•
RM 8555	821x523x623	115 / 12 lit.	122 lit.	135 W / 130 W	ca.2,6 KWh / 270 g	30 kg		•
RML 8550	1245x523x625	179 / 33 lit.	189 lit.	190 W / 170 W	ca.3,2 KWh / 380 g	45 kg	•	
RML 8551	1245x523x625	179 / 33 lit.	189 lit.	190 W / 170 W	ca.3,2 KWh / 380 g	45 kg		•
RML 8555	1245x523x625	179 / 33 lit.	189 lit.	190 W / 170 W	ca.3,2 KWh / 380 g	45 kg		•
RMSL 8550	1245x523x625	145 / 28 lit.	155 lit.	190 W / 170 W	ca.3,2 KWh / 380 g	40 kg	•	
RMSL 8551	1245x523x625	145 / 28 lit.	155 lit.	190 W / 170 W	ca.3,2 KWh / 380 g	40 kg		•
RMSL 8555	1245x523x625	145 / 28 lit.	155 lit.	190 W / 170 W	ca.3,2 KWh / 380 g	40 kg		•

RMS = stepped cabinet



**Flat door models**

Model	Dimensions H x W x D (mm) Depth incl. door	Gross capacity		Rating details mains/battery	Consumption * electricity/gas over 24hrs	Net weight	Ignition	
		with freezer compartment	without				Piezo	Automat
RMS 8500	821x523x541	86 / 9 lit.	92 lit.	125 W / 120 W	ca.2,5 KWh / 270 g	26 kg	•	
RMS 8501	821x523x541	86 / 9 lit.	92 lit.	125 W / 120 W	ca.2,5 KWh / 270 g	26 kg		•
RMS 8505	821x523x541	86 / 9 lit.	92 lit.	125 W / 120 W	ca.2,5 KWh / 270 g	26 kg		•
RMS 8550	821x523x596	99 /12 lit.	106 lit.	125 W / 120 W	ca.2,6 KWh / 270 g	27 kg	•	
RMS 8551	821x523x596	99 /12 lit.	106 lit.	125 W / 120 W	ca.2,6 KWh / 270 g	27 kg		•
RMS 8555	821x523x569	99 /12 lit.	106 lit.	125 W / 120 W	ca.2,6 KWh / 270 g	27 kg		•
RM 8500	821x523x541	96 / 9 lit.	102 lit.	135 W / 130 W	ca.2,4 KWh / 270 g	28 kg	•	
RM 8501	821x523x541	96 / 9 lit.	102 lit.	135 W / 130 W	ca.2,4 KWh / 270 g	28 kg		•
RM 8505	821x523x541	96 / 9 lit.	102 lit.	135 W / 130 W	ca.2,4 KWh / 270 g	28 kg		•
RM 8550	821x523x596	111 /12 lit.	118 lit.	135 W / 130 W	ca.2,6 KWh / 270 g	30 kg	•	
RM 8551	821x523x596	111 /12 lit.	118 lit.	135 W / 130 W	ca.2,6 KWh / 270 g	30 kg		•
RM 8555	821x523x596	111 /12 lit.	118 lit.	135 W / 130 W	ca.2,6 KWh / 270 g	30 kg		•

Subject to technical changes.

\*Average consumption measured at an average ambient temperature of 25°C in pursuance of ISO Standard.

## 4.0 Installation instructions

### 4.1 Installation



#### **WARNING!**

**The appliance may be installed by authorised personnel only!**

The unit and the exhaust duct system must be in principle installed so that it is accessible for maintenance work, can be easily installed and dismantled and removed from the vehicle without great effort.

Installation and connection of the appliance must comply with the latest technical regulations, as follows:

- **The electrical installation must comply with national and local regulations.**
- **Electrical wiring regulations**
- **The gas installation must comply with national and local regulations.**
- **AS 5601- Gas Installations**  
**NZ 5262 - Gas Appliance Safety**
- **The appliance must be installed in such a way that it is shielded from excessive heat radiation.**

Excessive heat impairs performance and raises the energy consumption of the refrigerator!



**Deviations from these installation instructions without prior notification of Dometic result in Dometic's warranty obligations becoming void!**

#### 4.1.1 Side installation

If the appliance is installed on the same side of the vehicle as the entrance door, it is desirable that the door does not cover the refrigerator's vents. (Fig. 5, Clearance door/ventilation grille at least 25 mm). Otherwise ventilation could be impaired which causes a loss in cooling performance. Awnings are often placed at the door side of a caravan. This complicates evacuation of combustion gases and heat through the ventilation grilles (loss in cooling performance)!

(Fig.5) The air vent grilles are blocked. There must be a distance between the door and the air vents of at least 25 mm!

If the door/grille distance is between 25 mm and 45 mm, we recommend installing a **Dometic ventilation kit** to achieve an optimal cooling performance in high ambient temperatures.

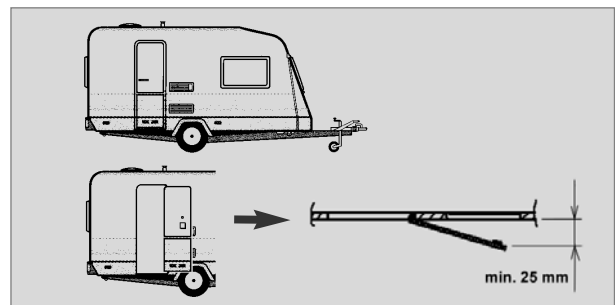

Fig. 5

(Fig. 6) The air vent grilles offer an unobstructed dissipation of heat and exhaust gas even when the door is opened.

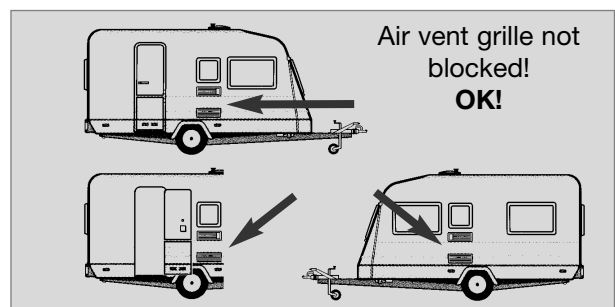

Fig. 6

**4.1.2 Rear installation**

Rear installation often causes an unfavourable installation arrangement, as ideal ventilation cannot always be assured (e.g. the lower ventilation grille is covered by the bumper or the rear lights of the vehicle!) (Fig. 8). The maximum cooling performance of the aggregate is actually not available.



Fig. 8



Fig. 9

Another unfavourable method of rear installation is to install the air intake and exhaust grilles (Fig. 10) at the side wall of the recreation vehicle. The air-heat recirculation is very restricted which means that heat exchangers (condenser, absorber) cannot be adequately cooled. The optional method of an additional air vent grille installed in the floor also exhibits an insufficient air flow duct.

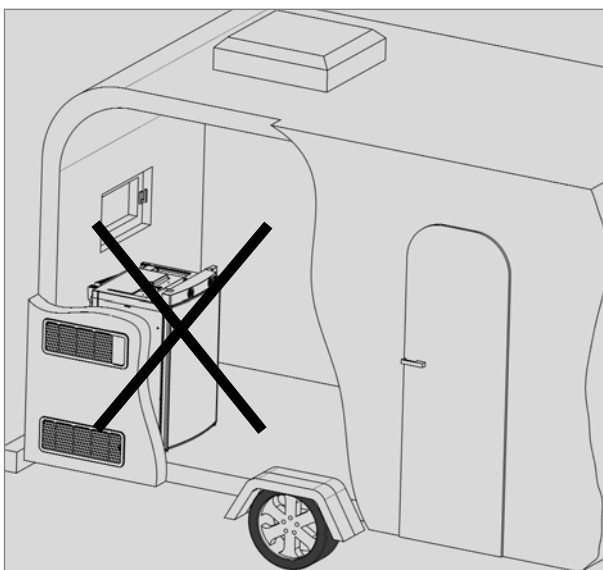

Fig. 10

**CAUTION!**

The maximum cooling performance is not available! Do not apply this installation method, as it does not provide proper ventilation! Please refer to the description in section 4.2 .

**4.1.3 Draught-proof installation**

Refrigerators in motorhomes, caravans or other vehicles must be installed in a draught-proof manner . This means that the combustion air for the burner is not taken from the living space and that exhaust fumes are prevented from entering the living space.

Adequate sealing between the back of the refrigerator and the vehicle interior has to be provided.

**Dometic** strongly recommends carrying this out using a flexible seal (in order to simplify later removal and installation of the unit for maintenance purposes.



**WARNING!**

By no means use durable sealing compounds, fitting foam or similar material to realise draught-proof installation of the refrigerator! Do NOT use any easily inflammable materials for sealing (in particular silicon sealing compound or similar). Risk of fire! The device manufacturer's product liability and warranty shall lapse if such materials are used.

**Proposal 1**

The lip seals (1) are installed at the bottom and on each side in the installation recess (Fig. 11-13). A heat deflector plate (2) is installed in the

installation recess above the refrigerator. **Affix the this plate to the caravan wall, do NOT attach to the refrigerator !**

Attach the deflector plate so that the heated air escapes through the top ventilation grill into the open air and no heat build-up can be produced.

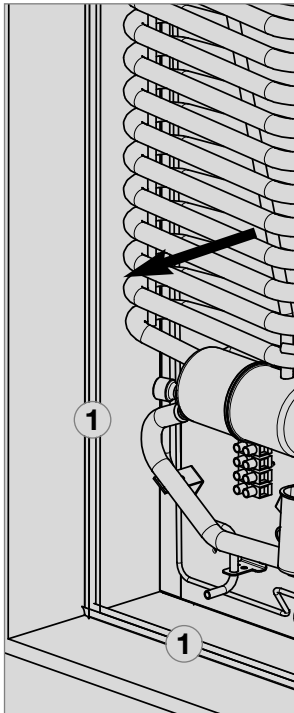

Fig. 11

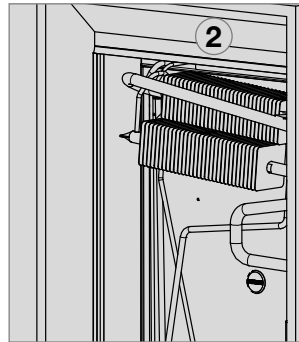

Fig. 12

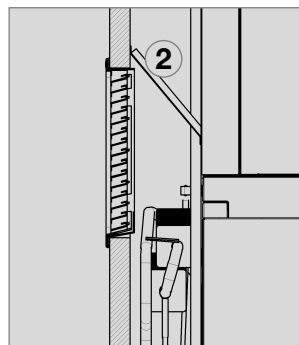

Fig. 13

The refrigerator is later pushed into the installation recess from the front. Ensure that the seals abut the case evenly.

This installation option facilitates the removal and installation of the appliance for servicing.

**Proposal 2**

Fasten the sealing lips to a stop bar on the rear side (1), e.g. by gluing.

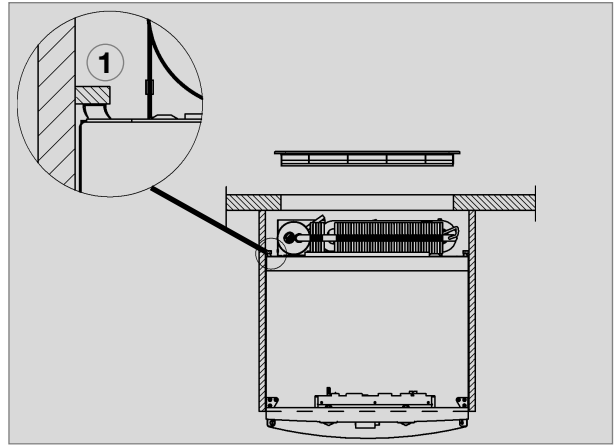

Fig. 14/15

The cavity in-between the outer vehicle wall and refrigerator is completely isolated from the vehicle interior. Intrusion of exhaust fumes into the living space is prevented. Fumes will escape through the upper ventilation grille to the outside.



**Deviations require the consent of the manufacturer!**

## 4.2 Ventilation and air extraction of the refrigerator

A correct installation of the refrigerator is essential for its correct operation, as due to physical reasons heat builds up at the back of the appliance which must be allowed to escape into the open air.



**In the event of high ambient temperatures, full performance of the cooling unit can only be achieved by means of adequate ventilation and extraction.**

Ventilation is provided for the unit by means of two apertures in the caravan wall. Fresh air enters at the bottom, extracts the heat and exits through the upper vent grille (chimney effect). **The upper ventilation grille should be positioned as high as possible above the condenser (A, Fig. 18, 22). Install the lower ventilation grille at floor level of the vehicle,** allowing unburnt gas (heavier than air) to escape directly into the open air. An optional ventilation aperture can be introduced by the manufacturer of the vehicle into the recess floor in order to avoid the accumulation of unburnt gas on the floor (Fig.18).

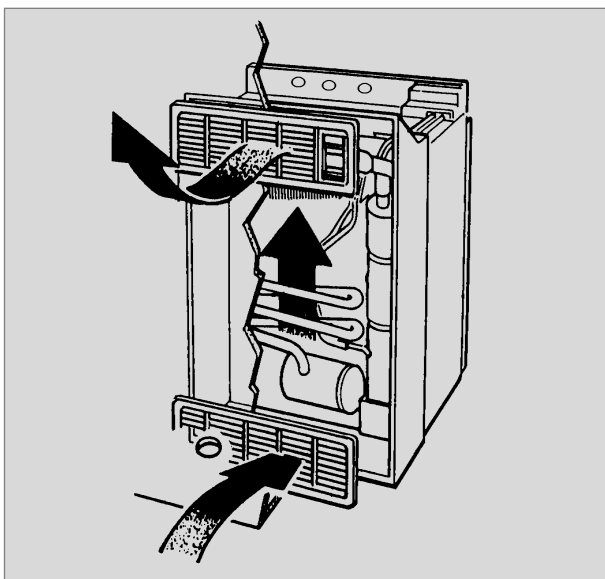

Fig. 17

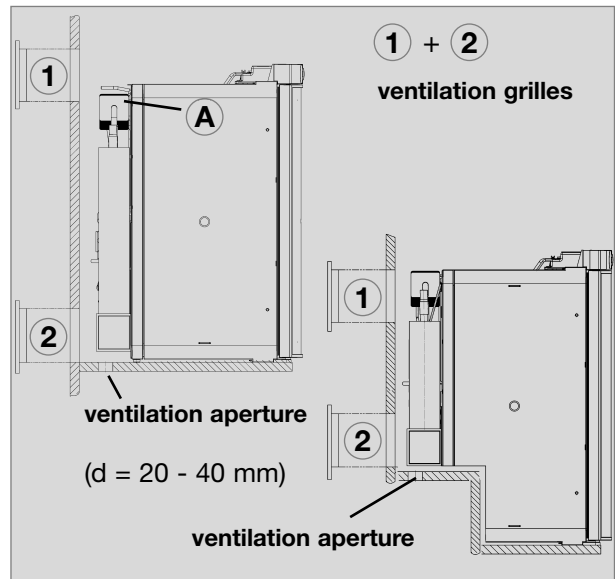

Fig. 18

## 4.3 Installing the ventilation system

### 4.3.1 Ventilation systems for small refrigerators (120 ltr. cap. or less)

**Dometic** recommends the **A 1625** ventilation and flue gas extraction system which has been tested and approved for this purpose. These ventilation grilles provide the required open cross-section of at least 250 cm<sup>2</sup>.

LS 100

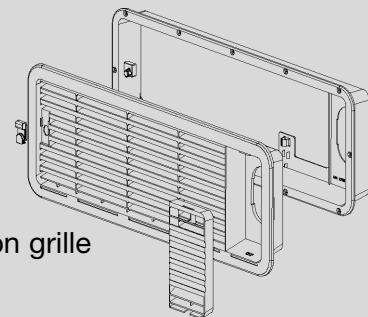

Top ventilation grille with flue

Fig. 19

LS 200

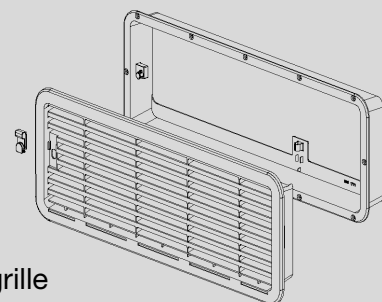

Lower ventilation grille

Fig. 20

### 4.3.2 Ventilation systems for large refrigerators (larger than 120 ltr. cap.)

**Dometic** recommends the larger LS 300 side ventilation grilles be used for both the top and lower side ventilation of the refrigerator. Alternatively, the installation of the lower ventilation grille (LS 300) with the roof exhaust is also acceptable.

The ventilation grilles must have an open cross-section of at least 400 cm<sup>2</sup>. This is achieved by using the Dometic LS300 absorber ventilation and air extraction system which has been tested and approved for this purpose.

#### Positioning of roof exhaust R500 and lower ventilation grille LS300

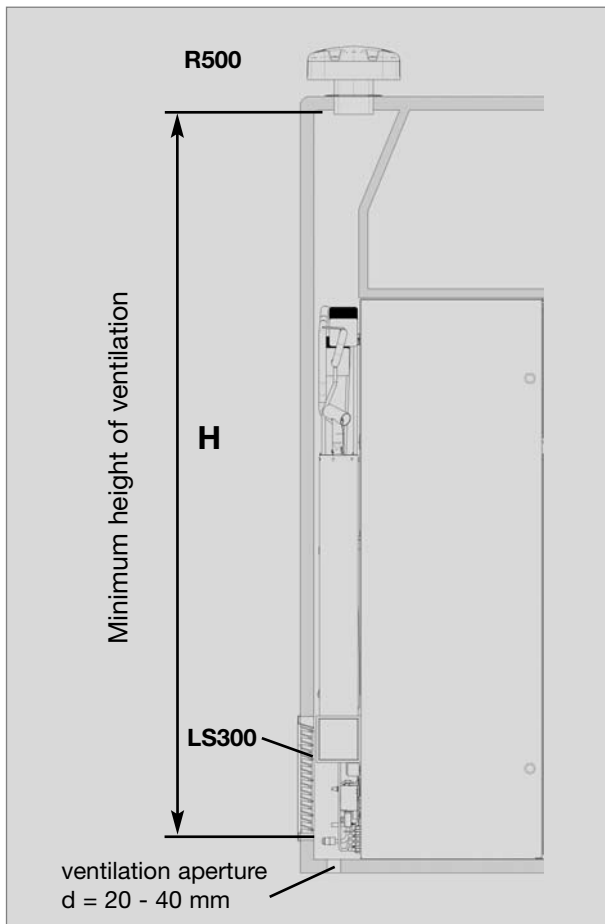

Fig. 21

#### Positioning of of lower and upper ventilation grilles LS300

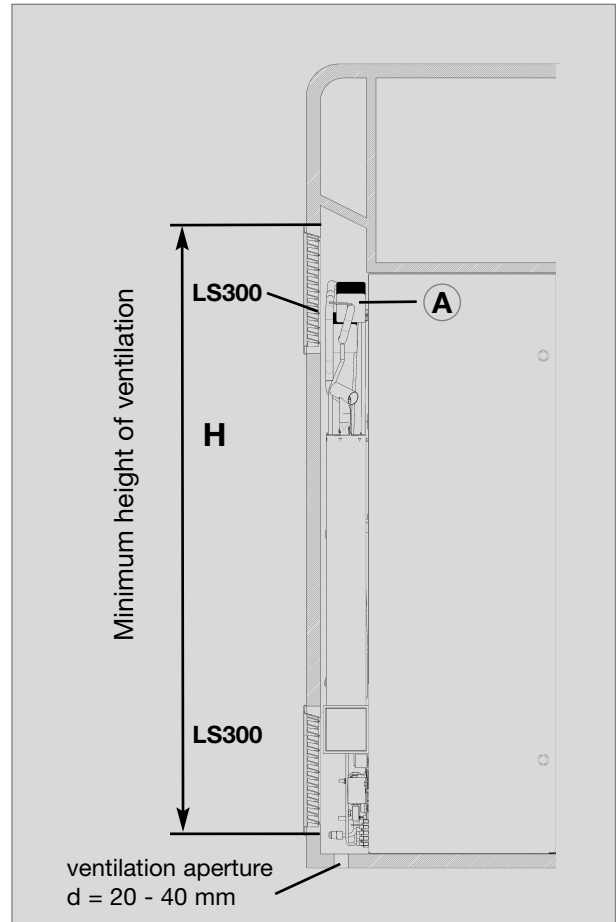

Fig. 22

Minimum height of ventilation H	
1.	
Roof exhaust R500	
Lower vent grille LS300	<b>1250 mm</b>
2.	
Upper vent grille and lower vent grille LS300	<b>1400 mm</b>



Correct mounting of the lower ventilation grille facilitates access to the connections and functional parts during maintenance.

**4.3.3 Installing LS 100/LS 200 or LS 300**

To install the ventilation grilles **LS 200**, cut two rectangles (451mm x 156mm) in the outer wall of the vehicle (for position of the cuts, see Fig. 16).

To install the ventilation grilles **LS 300**, cut two rectangles width **b = 490mm**, height **a 249mm**, in the outer wall of the vehicle (for position of the cuts, see Fig. 21,22).

**LS 100**

**1**

Seal the mounting frame making it waterproof (does not apply for mounting frames with integral seal).

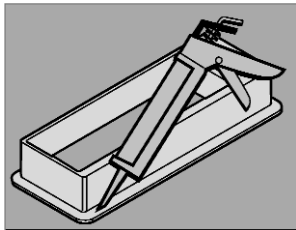

Fig. 23

**2**

Insert frame and screw into position

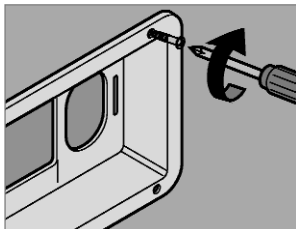

Fig. 24

**3**

Insert and lock ventilation grille.

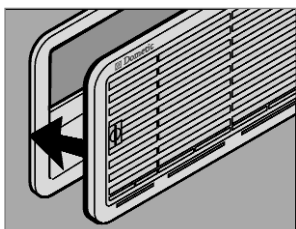

Fig. 25

**4**

Clip the insert for flue gas duct in position (only for L100 upper ventilation system kit).

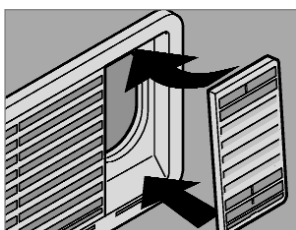

Fig. 26

**LS 200 / LS 300**

**1**

Cut two rectangles in the exterior wall of the vehicle.

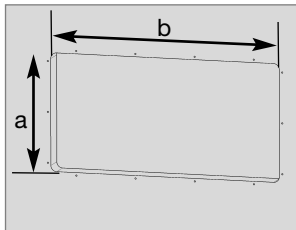

Fig. 27

**2**

Seal the mounting frame making it waterproof (does not apply for mounting frames with integral seal) and screw into position.

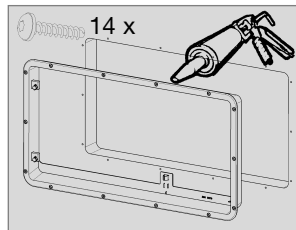

Fig. 28

**3**

Insert ventilation grille.

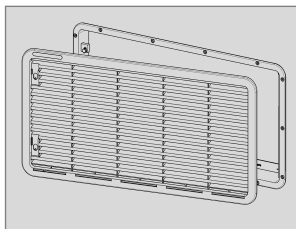

Fig. 29

**4**

Install locking slider.

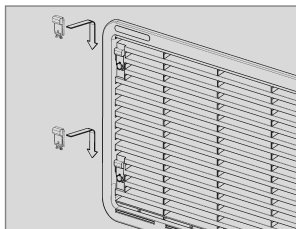

Fig. 30

**5**

Lock ventilation grille.

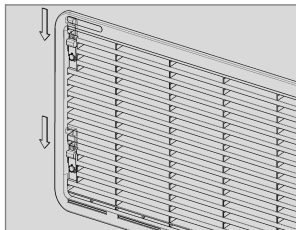

Fig. 31

### 4.3.4 Installing roof exhaust R500

#### Measurements of roof exhaust R500

Length	Width	Height
595 mm	205 mm	150 mm
Roof cut out: 87mm X 507 mm		

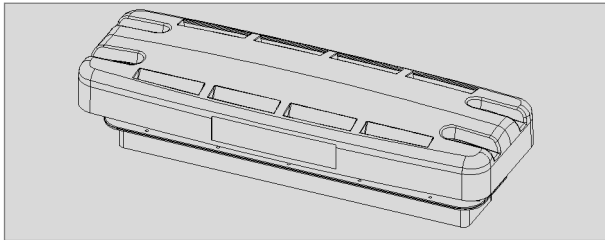

Fig. 32

**1**

Seal the installation bays and screw them to the vehicle roof.

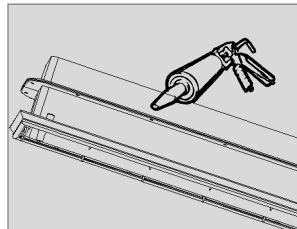

Fig. 33

**2**

Place the hood in position and screw it to the installation bays.

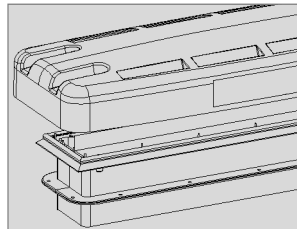

Fig. 34

## 4.4 Exhaust gas duct and installing the fume flue

The exhaust gas duct system must be made in such a manner as to achieve a complete extraction of combustion products to the outside of living space. The duct system must slope in an upward direction in order to avoid a build-up of condensate. The type of exhaust gas duct shown in Fig. 35 allows the side installation of the winter cover.

### CAUTION!

An installation other than described will reduce the cooling capacity and jeopardise the manufacturer's warranty/product liability.

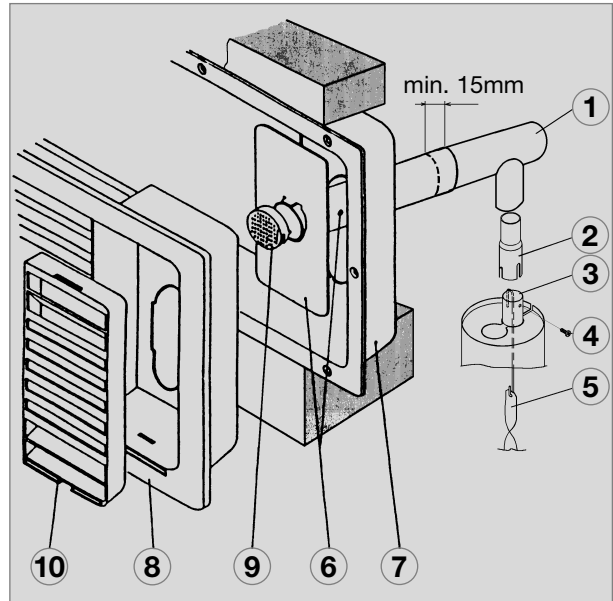

Fig. 35

### Installing the standard fume flue

1. Connect T-piece (1) to adaptor (2) or flue pipe (3) as required and affix with screw (4). Ensure that heat baffle (5) is lodged in the correct position.
2. Insert flue pipe with cover plate (6) through the appropriate aperture in the upper frame (7) and connect to T-piece (1). If necessary, shorten flue pipe (6) to the required length.
3. Insert and lock ventilation grill LS 100 (8) in the mounting frame (7).
4. Put cap (9) on flue pipe (6).
5. Insert extractor insert (10) into ventilation grille (8).



## 4.5 Installation recess

The refrigerator must be installed draught-proof in a recess (also refer to Section "4.1.4"). The measurements of the recess are stated in the table below. **Step (1)** (Fig. 36) is only required for cabinets with a step. The floor of the recess must be level, allowing the appliance to be pushed easily into its correct position. The floor must be substantial enough to bear the weight of the appliance.

### 4.5.1 Installation in the recess

Push the appliance far enough into the recess until the front edge of the refrigerator casing is aligned with the front of the recess. Allow a **gap of 15-20 mm** between the back wall of the recess and the refrigeration unit.

**Ensure that the refrigerator is installed level in the recess.**

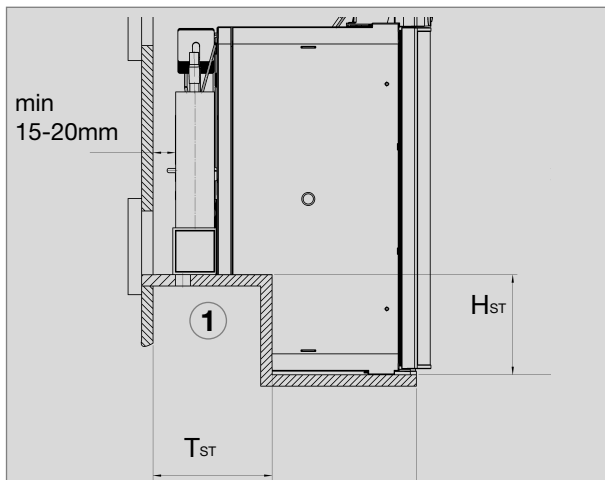

Fig. 36

Model	Height H <sub>ST</sub>	Depth T <sub>ST</sub>
RMS 8400	220 mm	235 mm
RMS 8401	220 mm	235 mm
RMS 8405	220 mm	235 mm
RMS 8460	220 mm	235 mm
RMS 8461	220 mm	235 mm
RMS 8465	220 mm	235 mm
RMS 8500	220 mm	235 mm
RMS 8501	220 mm	235 mm
RMS 8505	220 mm	235 mm
RMS 8550	220 mm	235 mm
RMS 8551	220 mm	235 mm
RMS 8555	220 mm	235 mm
RMSL 8550	220 mm	235 mm
RMSL 8551	220 mm	235 mm
RMSL 8555	220 mm	235 mm

### 4.6 Securing the refrigerator

In the sidewalls of the refrigerator, there are four plastic sleeves for securing the refrigerator. The sidewalls or strips attached for securing the refrigerator must be prepared to hold the screws firmly in place even when under increased load (while the vehicle is moving). Fastening screws and caps are supplied with the refrigerator.

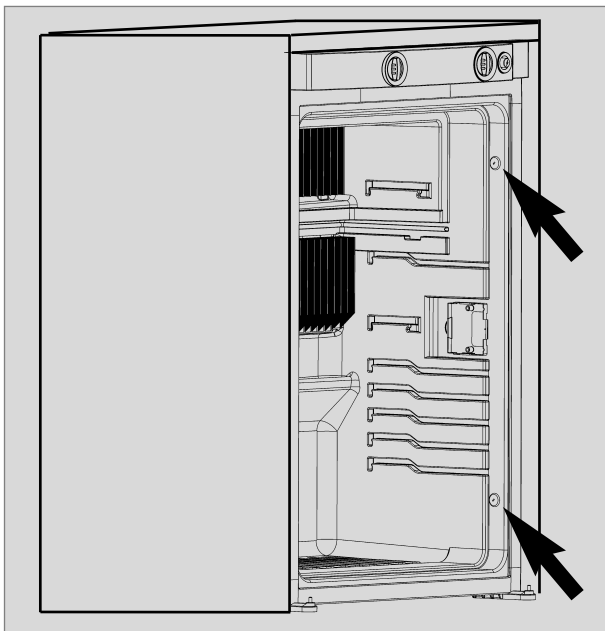

Fig. 37

**CAUTION!**  
 Always insert screws through the sleeves provided as otherwise components laid in foam, such as cables etc., could be damaged.

After the refrigerator is put in its final place, secure the screws into the wall of the recess. The screws must penetrate the casing of the refrigerator.

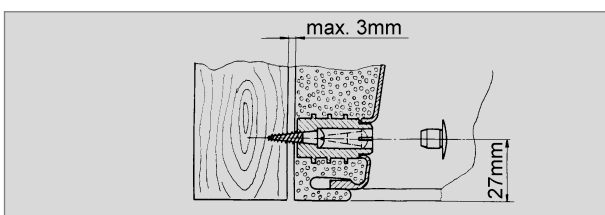

Fig. 38

### 4.7 Inserting the decor panel

**Model RM 8xxx, RMS 8xxx**

- Remove the lateral ledge (1) the door (ledge is attached, not screwed).
- Shift decor panel (2) away from the door and insert the new decor panel. Re-attach ledge (1).

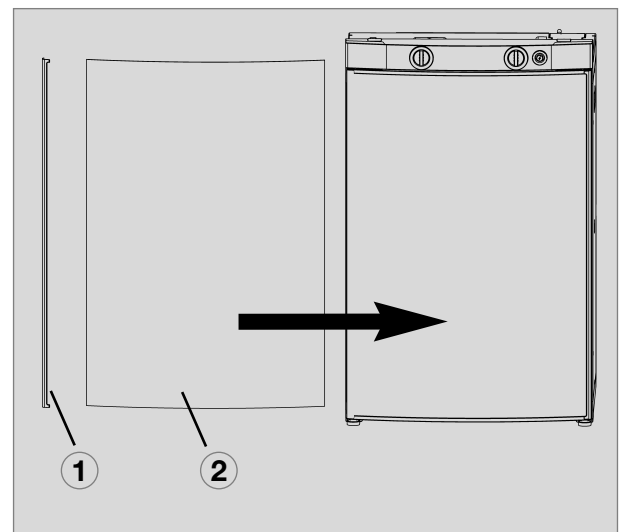

Fig. 39

#### Decor panel dimensions :

<b>Casing width</b>	486 mm	
<b>Height</b>	<b>Width</b>	<b>Thickness</b>
743 +/- 0.5 mm	472 +/- 0.5 mm	max. 2.2 mm

<b>Casing width</b>	523 mm	
<b>Height</b>	<b>Width</b>	<b>Thickness</b>
743 +/- 0.5 mm	510,5 +/- 1 mm	max. 2.2 mm

**Model RML 8xxx**

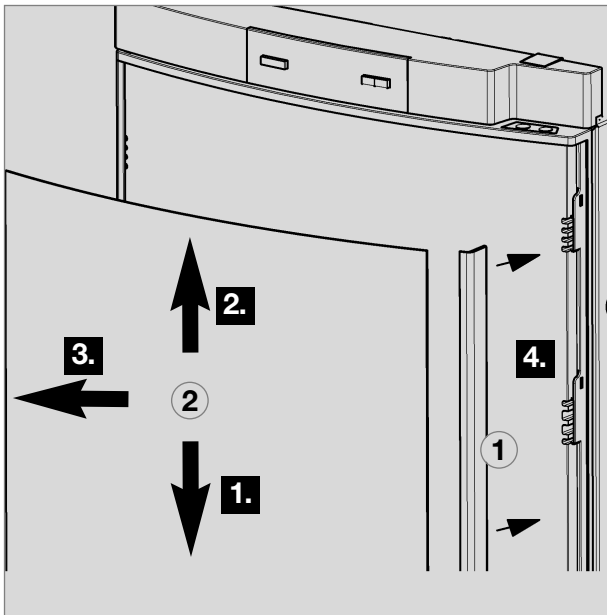

Fig. 40

**CAUTION!**

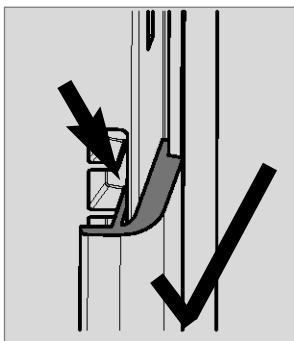

Fig. 41

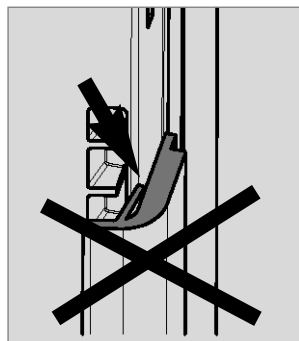

Fig. 42

**Decor panel dimensions :**

<b>Casing width</b>	523 mm	
<b>Height</b>	<b>Width</b>	<b>Thickness</b>
1169,5 +0/-1 mm	507,5 +0/-1 mm	max. 1.7 mm

**Model RML 8xxx, frameless decor panel**

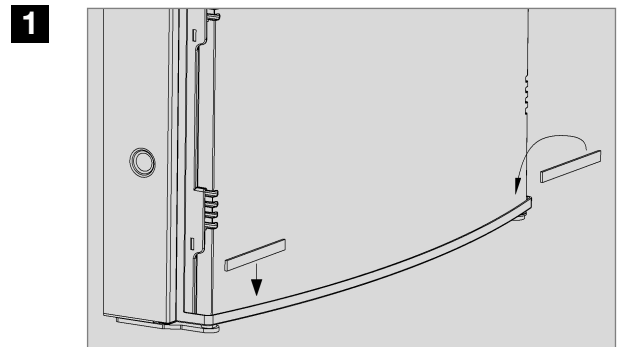

Fig. 43

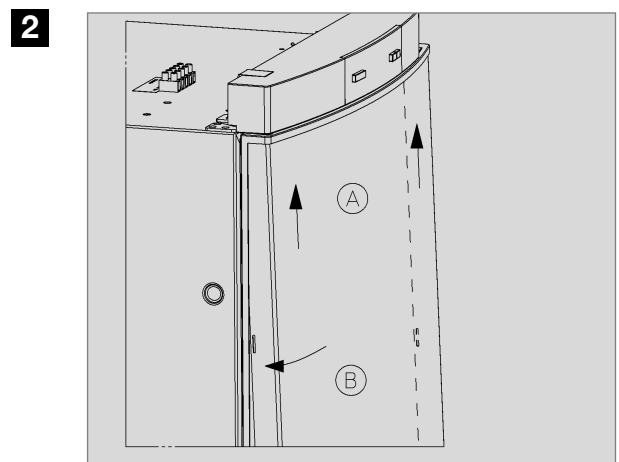

Fig. 44

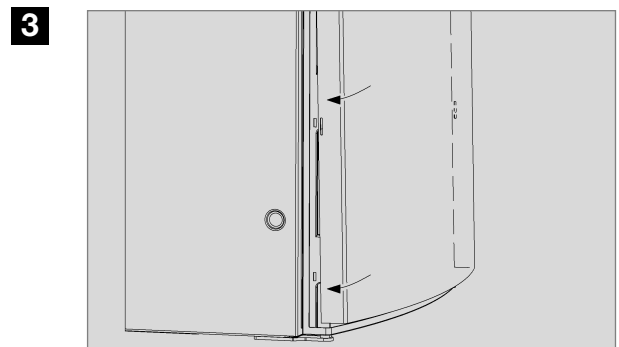

Fig. 45

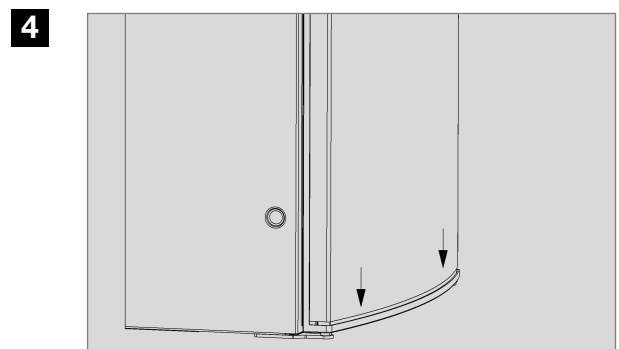

Fig. 46

## 4.8 Gas installation



### WARNING!

The gas connection shall be carried out by specialised personnel\* only.

\* Specialised personnel are accredited experts who are able, by virtue of their training and knowledge, to vouch for the correct installation and implementation of the leakage test.

- Observe the regulations stated in section 2.1 .
- This refrigerator is provided for installation within liquid gas equipment and must be run exclusively on liquid gas (propane, butane) (no natural gas, town gas).
- An AGA Approved LP Regulator must be fitted to the gas supply. The pressure regulator must concur with the operating pressure specified on the rating plate of the appliance. The operating pressure corresponds to the standard pressure of the country of specification.
- Only one connection pressure is permissible for any one vehicle! A plate showing the permanent, clearly legible notice must be displayed in full view at the point where the gas cylinder is installed.
- The gas connection to the appliance must be installed securely and free of stress using pipe connectors and must be securely connected to the vehicle (a hose connection is not permissible) .
- The gas connection to the appliance is 1/8" BSP Female (s. figure 47).
- The refrigerator must be equipped with a shut-off valve allowing to cut the supply line. Such a shut-off device must be readily accessible to the user.

Before Leaving - Check all connections for gas leaks with soap and water. DO NOT use a naked flame for detecting leaks. Ignite the burner to ensure correct operation of gas valve, burner and ignition. When satisfied with the appliance, please instruct the user on the

correct method of operation. In case the appliance fails to operate correctly after all checks have been carried out, refer to the authorised service provider in your area.

### Gas connection

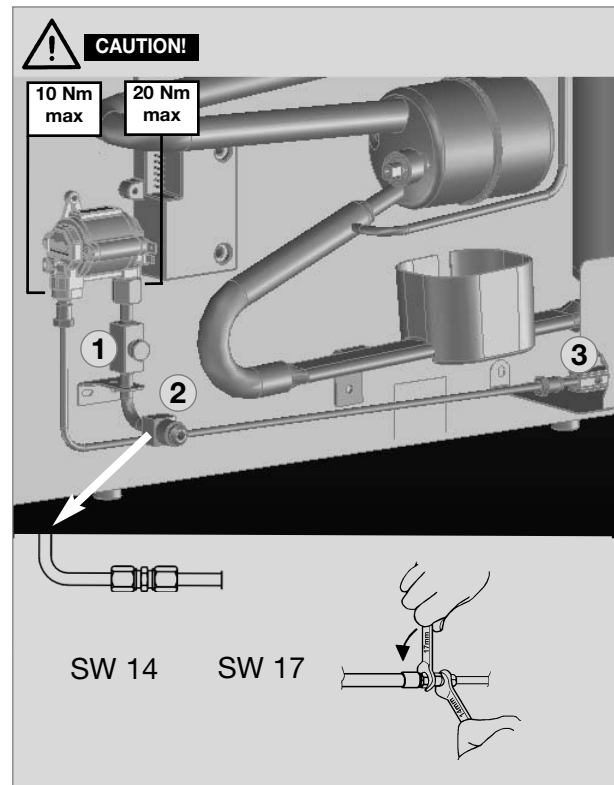

Fig. 47

- ① Testing point
- ② Connection to gas supply
- ③ Gas burner

### Gas pressure

Refer to data label.



The refrigerator must be equipped with a gas cock in the supply line to allow the supply to be disconnected. Such a cut-out device must be readily accessible to the user.

When using **LPG gas (tank)**, please consider that the burner needs cleaning at shorter intervals due to the gas combustion method (2 - 3 times per year recommended).



The refrigerator must be equipped with a gas cock in the supply line to allow the supply to be disconnected. Such a cut-out device must be readily accessible to the user.

When using **LPG gas (tank)**, please consider that the burner needs cleaning at shorter intervals due to the gas combustion method (2 - 3 times per year recommended).

## 4.9 Electrical installation

**WARNING!**

**The electrical installation shall be carried out by qualified personnel only.**

*\* Specialised personnel are accredited experts who are able, by virtue of their training and knowledge, to vouch for the correct installation.*

- **The electrical installation must be in accordance with the national regulations of the respective countries.**
- **The connection cables must be routed in a way to prevent contact with hot components of the unit/burner or with sharp edges.**
- **Changes to the internal electrical installation or the connection of other electrical components (e.g. external fan) to the internal wiring of the appliance will render the e1/ CE admittance as well as any claims from warranty and product liability void!**

### 4.9.1 Mains connection

- **The power should be supplied by a properly grounded socket outlet or a grounded non-detachable connection. Where a socket outlet with mains supply is used, the outlet must be freely accessible. Should the connection cable be damaged, have it replaced by Dometic**

### Customer Services or by qualified personnel to avoid hazards.

We recommend leading the power supply via a board-side fuse protection.

### 4.9.2 Battery connection

The machine's 12V connection cable is connected (observing correct polarity) to a terminal strip (RMx 8xx0) or plug-in-contacts (RMx 8xx1, 8xx5). The wiring for the 12V heating element (refer to A, B wiring diagram connections) must be direct and by the shortest possible route to the battery or electric generator.

#### Provide a 20 A fuse to protect on-board 12V circuit.

In order to ensure that the 12V power supply is shut off when stopping the engine (otherwise the battery would discharge within a few hours), perform the power supply to the 12V heating element (connection A/B in wiring diagram) in a way to have the 12V supply only live while the vehicle ignition is switched on.

The connection C/D (interior light, electronics) must be permanently provided by a 12V DC power supply to be protected by a 2A fuse.

**CAUTION!**

**If the appliance is installed in a caravan the respective leads for the 12V+ and 12V-connections A/B and C/D must not be connected to each other on the caravan-side (EN 1648-1).**

#### Cable cross sections and cable lengths :

##### Motorcaravan & Caravan (inside)

4 mm <sup>2</sup> (RML 8xxx = 6 mm <sup>2</sup> )	< 6 m
6 mm <sup>2</sup> (RML 8xxx = 10 mm <sup>2</sup> )	> 6 m

##### Caravan (outside)

min 2,5 mm<sup>2</sup>

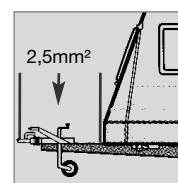
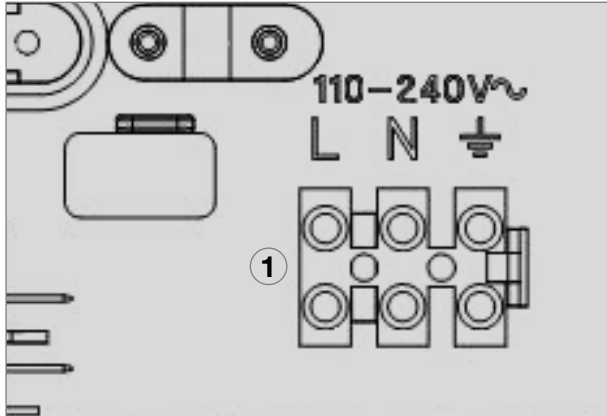

Fig. 48

### 4.9.3 Cable connections

#### Connections for models RM(S) 8xx0



Mains connection

Fig. 39

- 1 L = brown
- N = blue
- Earth = yellow/green

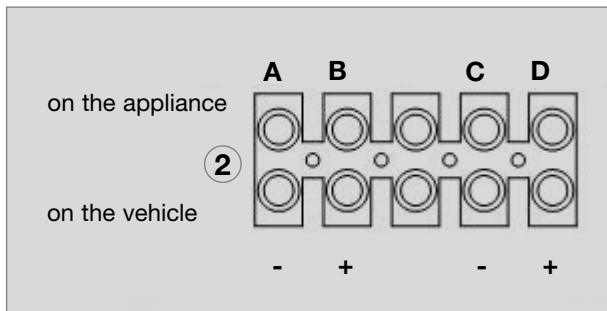

12V connection

Fig. 40

- 2 A = Ground heating element DC (brown)
- B = Positive connection, heating element DC (brown)
- C = Ground interior lighting (black)
- D = Positive connection lighting (white)

#### Connections for models RM(S) 8xxx (MES), RM(S) 8xx5 (AES) :



For MES and AES it is compulsory to provide a permanent 12V DC supply at the terminals C/D (permanent voltage supply for functional electronics).

The power supplies for electronics and heating element are connected directly at the plug-in contacts of the electronics.

#### Position of the control electronics :

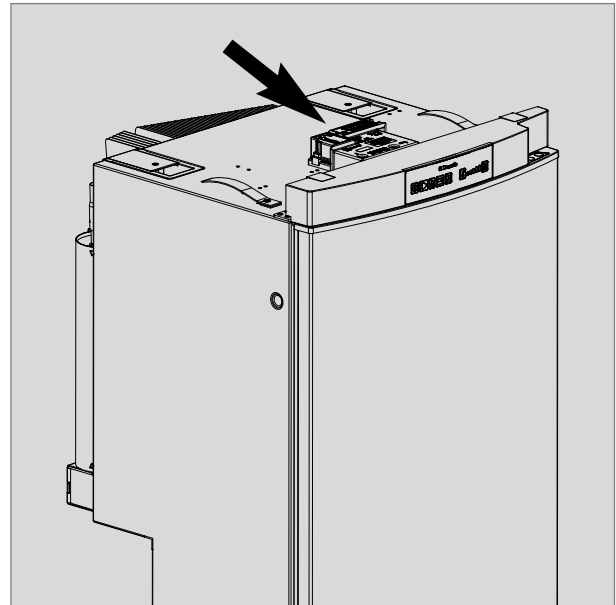

Stepped cabinet models

Fig. 41

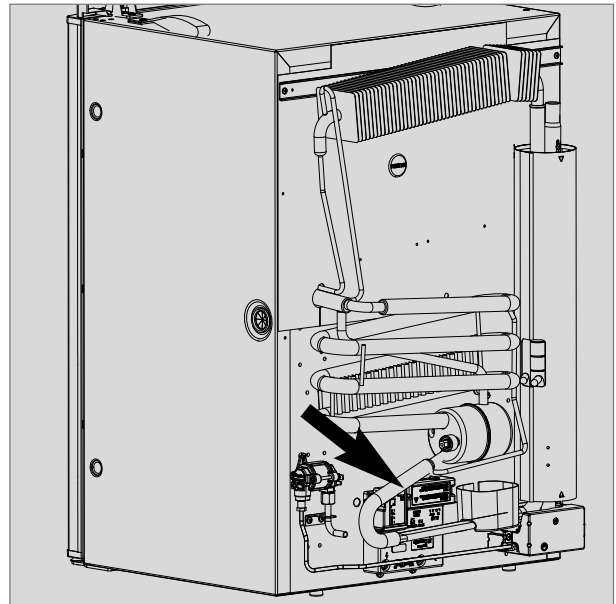

Standard models

Fig. 42

**Contacts at the electronics:**

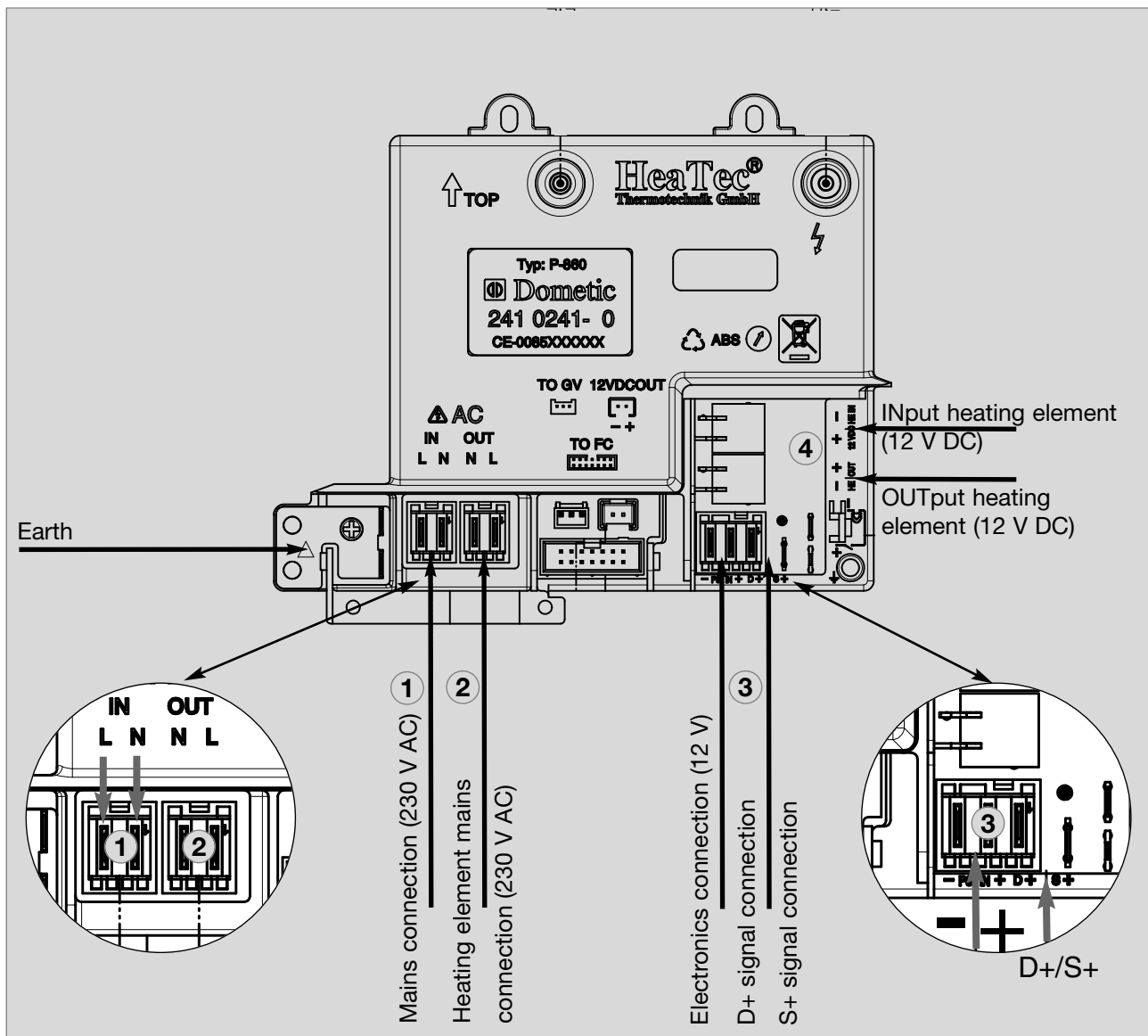

Fig. 43

**Plug-in contacts (manufacturer: Stocko® )**

- ① MF 9562-002-80E
- ② MF 9562-002-8 OC
- ③ 3-pin with D+ contact: MF 9562-003-8 30 960-000-00  
2-pin : MF 9562-002-8 ON + spade connector 6.3 x 0.8
- ④ MKH 5132-1-0-200

#### 4.9.4 D+ and solar connection (only for AES models)

##### D+ signal connection

In **>Automatic Mode<** the **AES** electronic system automatically selects the most efficient energy supply. In automatic mode the electronic system uses the **D+ signal** (dynamo +) of the alternator to detect **12V DC**. 12V DC operation is selected only while the engine is running in order to prevent battery discharge.

##### S+ signal connection:

12V DC energy can be optionally achieved by mounting solar equipment to the vehicle. The solar power equipment must be provided with a solar charging controller with **AES output** (adequate charging controllers available in selected stores). The "S+ connection (Solar +) must be connected to the respective terminal of the solar charging controller (**AES output**). The electronic system uses the **S+ signal** of the solar charging controller to detect **solar 12V DC**.

##### Cable cross-sectional areas:

There are no particularly high current flows via the D+ and S+ connection; therefore no particularly large cross-section is required for these connections (approx. 1mm<sup>2</sup> is sufficient).



**4.9.5 Circuit diagrams**

**Circuit diagram RM(S) 8xx0 :**

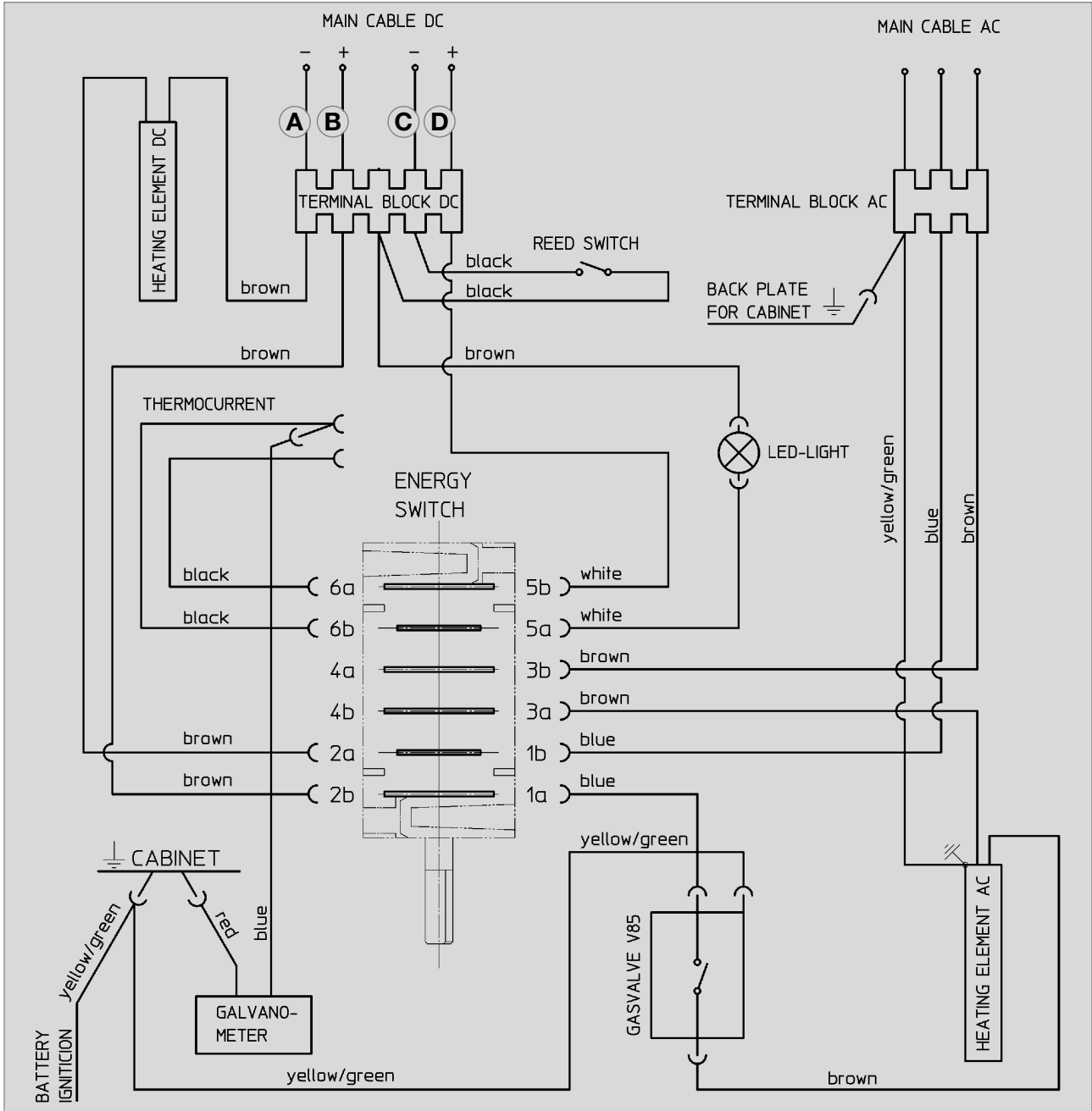

Fig. 44

Circuit diagram RM(S) 8xx1, RM(S) 8xx5 :

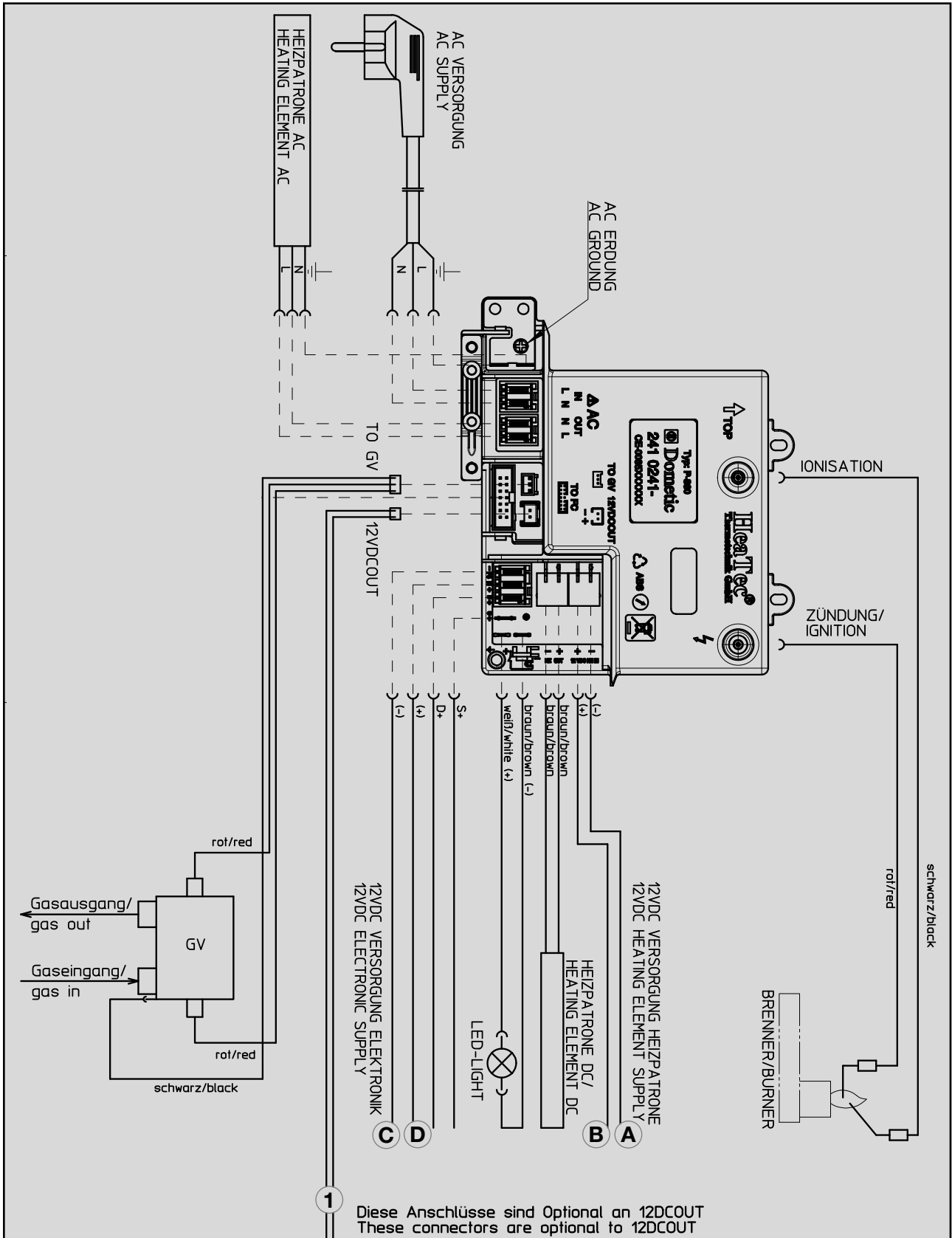
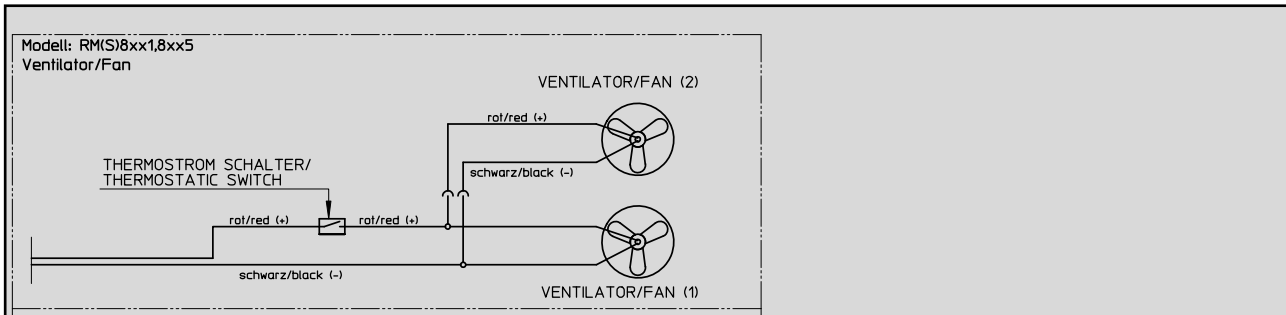

Fig. 45

**Fan (optional) RM(S) 8xx1, RM(S) 8xx5 :**



- ① = 12V OUT / 12 V power supply for optional connections
- Ⓐ = Ground connection heating element 12VDC
- Ⓑ = Positive connection, heating element 12VDC
- Ⓒ = Ground connection electronics 12VDC
- Ⓓ = Positive connection electronics 12VDC



**For MES and AES it is compulsory to provide a permanent 12V DC supply at the terminals C/D (permanent voltage supply for functional electronics).**

**CAUTION!**  
Under no circumstances can this permanent DC supply be 24 V.

