

The DENSO logo is located in the top left corner of the page. It consists of a red horizontal bar with a white curved shape on the left side, and the word "DENSO" in white, italicized, uppercase letters on the right side.

DENSO

UB1 AIR CONDITIONING UNIT INSTALLATION INSTRUCTIONS

Published: June 2012

DENSO AUTOMOTIVE SYSTEMS AUSTRALIA PTY. LTD

AL00500054E

© 2012 DENSO Automotive Systems Australia Pty. Ltd

All rights reserved.

This material may not be reproduced or copied, in whole or in part, without the written permission of DENSO Automotive Systems Australia.

TABLE OF CONTENTS

Operation

1.	FOREWORD	1
1.1	Definition of Terms	1
2.	INVENTORY	1
3.	GENERAL INFORMATION	2
4.	CONTROLS	4
4.1	Remote Control.....	4
4.2	Unit.....	6
5.	OPERATION	7

Repair

6.	MAINTENANCE	9
6.1	Inlet Air Filter.....	9
6.2	Under Floor Vents.....	9
6.3	Remote Control Batteries	10
6.4	General Condition.....	11
7.	TECHNICAL DATA	11
7.1	Wiring Diagram	12
8.	TROUBLESHOOTING	13
9.	WARRANTY DETAILS	15
—	Warranty Registration Card	

3. GENERAL INFORMATION

- 3.1 The ability of the air-conditioner to maintain a desired temperature depends upon the heat entering or leaving your vehicle. The following simple guidelines should be followed to achieve the best comfort, lowest energy use and quietest operating noise.
- a. Park your vehicle in a shaded area
 - b. Keep all windows, doors, curtain and blinds closed while operating
 - c. Select higher fan speeds for higher cooling performance
 - d. Switch your air-conditioner to cooling early in the day before the vehicle interior has become too hot.
 - e. If the vehicle interior is already hotter than the outside air, briefly open doors and windows to exhaust the hot air before starting the air-conditioner cooling.
 - f. Avoid using stoves and ovens that add heat to the vehicle interior while the air-conditioner is cooling.
- 3.2 In humid conditions, the operation of an air-conditioner can cause the formation of condensate on cold surfaces inside your vehicle. Care must be taken to prevent this condensate damaging personal items, or causing a build up of mould. Items that may be damaged by condensate must be kept clear of the air duct. In rare circumstances, condensate can form on this duct during use. Should condensate form, allow to dry thoroughly after use.

NOTE: Condensation can be reduced by keeping all doors and windows closed during air-conditioner operation, preventing humid air from entering the vehicle. The likelihood of condensation on the duct can be reduced by closing the doors of any cupboards that the duct passes through.

WARNING

If the supply cord is damaged, it must be replaced by the manufacturer, its service agent or similarly qualified persons in order to avoid a hazard.

All electrical work, if necessary, should only be performed by qualified electrical personnel. Repair to electrical components by non-certified technicians may result in personal injury and/or damage to the unit. All electrical components replaced must be genuine replacement parts, purchased from an authorised reseller.

1. FOREWORD

Thank you for purchasing the AAA UB1 Air Conditioning Unit. Before using the unit, thoroughly read this manual and follow the instructions on how to operate this product. Keep this manual in the caravan, and in case the caravan is sold to another party, make sure that this manual is passed on to the next owner.

1.1 Definition of Terms

WARNING

Describes precautions that should be observed in order to prevent injury to the user during unit operation.

CAUTION

Describes precautions that should be observed in order to prevent damage to the unit or its components, which may occur during unit operation if sufficient care is not taken.

NOTE: Provides additional information that facilitates unit operation.

2. INVENTORY

After unpacking your unit, please check to make sure you have the following items:

1. UB1 Unit (1)
2. Air Distribution Unit (2)
3. Remote Control, Bracket & Batteries (3)
4. Air Distribution Unit Label for Upside-Down Installation (1)
5. Operation Manual (1)

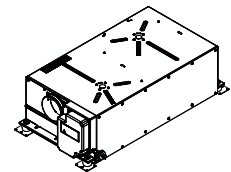

1. UB1 UNIT

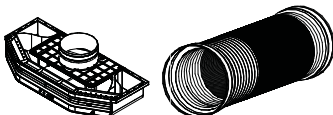

2. AIR DISTRIBUTION UNIT

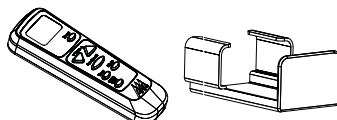

**3. REMOTE CONTROL,
BRACKET & BATTERIES**



4. LABEL

NOTE: If any of these items are not included in the box or appear damaged, please contact your reseller for replacement.

⚠ WARNING

This appliance is not intended for use by persons (including children) with reduced physical, sensory or mental capabilities, or lack of experience and knowledge, unless they have been given supervision or instruction concerning use of the appliance by a person responsible for their safety.

Children should be supervised to ensure that they do not play with this appliance.

This unit must be connected to a power outlet that allows for disconnection from the supply after installation. In the event of a fault, immediately disconnect the unit & contact a service agent for assistance.

- a. The unit fuse and supply cord should only be replaced by a licensed electrician. The fuse is located in the electrical control housing on the side of the unit. Fuse rating is: 250V/500VAC, 10A, T-Delay, 5x20mm.
 - b. The air-conditioner must be disconnected from the power supply before any disassembly or repairs.
 - c. The air-conditioner uses the refrigerant R407C under high pressure. It is both dangerous and illegal to tamper with the sealed refrigerant system without appropriate licensing. Deliberate release of refrigerant is illegal in Australia.
- 3.3 The air intake, exhaust and condensate drain under the floor of the vehicle must be kept clear of any material that may block airflow. Failure to keep these areas clear could cause poor performance, water leakage into your vehicle and permanent damage to the air-conditioner.
- 3.4 The interior air intake on the side of the air-conditioner must always be kept clear. A minimum 40mm gap is required from any fixed wall, and personal belongings must not be placed near the inlet.
- 3.5 The air-conditioner must never be operated while the vehicle is moving. The vehicle should be parked with the unit tilted no more than 8° from horizontal.
- 3.6 This unit is designed to be operated on 230-240V 50Hz power from the electricity grid or a sine wave inverter equipped generator. The recommended generator capacity for this unit is 2.8kVA.

4. CONTROLS

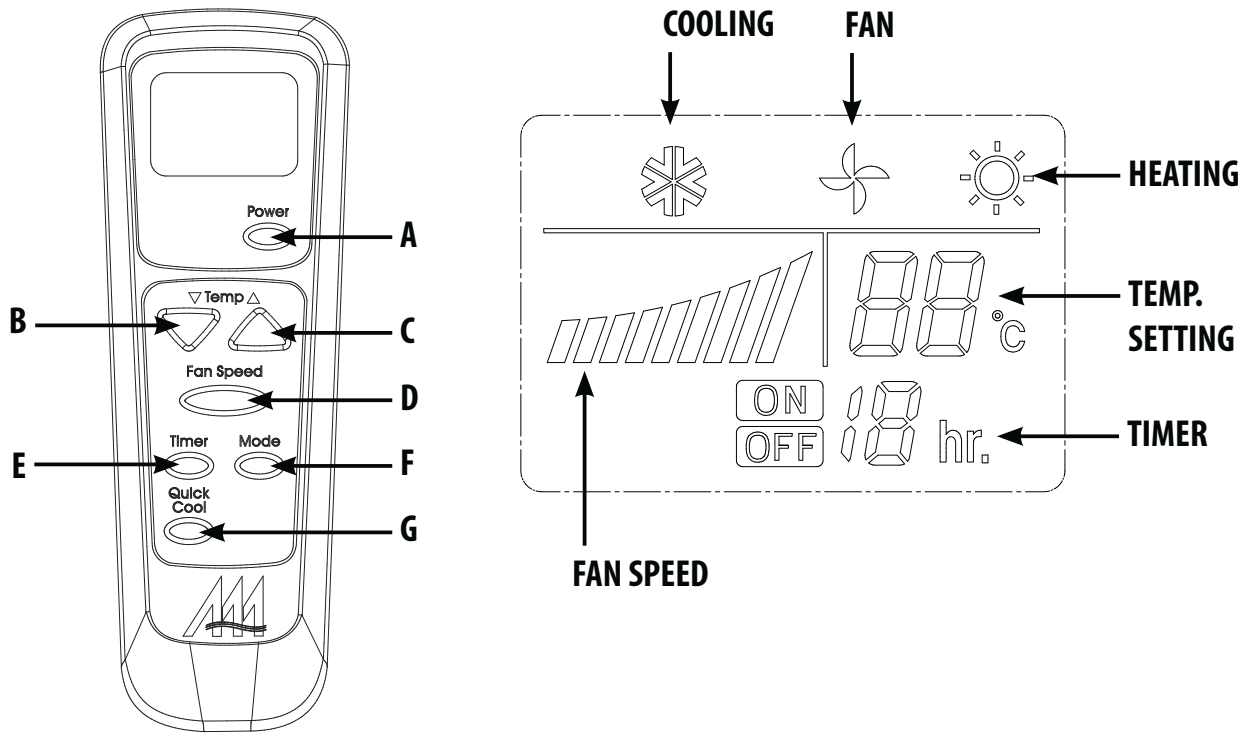

4.1 REMOTE CONTROL

A/ Power

On/Off switch

B/ Temperature Decrease

Lowers the desired room temperature (16-30°C)

C/ Temperature Increase

Raises the desired room temperature (16-30°C)

D/ Fan Speed

Cooling/Fan Mode

Cycles the interior fan through 3 speed settings

Heating Mode

Fan speed is controlled automatically regardless of remote setting.

E/ Timer***On Timer***

Pressing this button while the unit is off will set the on timer. Each button press adds 1 hour to the wait time until the unit starts (1-12 hours). After cycling through 12 hours, the next button press will cancel the on timer.

Off Timer

Pressing this button while the unit is on will set the off timer. Each button press adds 1 hour to the wait time until the unit stops (1-12 hours). After cycling through 12 hours, the next button press will cancel the off timer.

F/ Mode

Cycles through the 3 modes of air-conditioner operation.

Fan Mode

Used for ventilation only. Fan speed can be changed between low, med and high by pressing D- Fan Speed.

Cooling Mode

The compressor and external fans will operate automatically to cool the cabin to achieve the desired temperature. Fan speed can be adjusted between low, med and high by pressing D- Fan Speed.

Heating Mode

The compressor and external fans will operate to heat the cabin to achieve the desired temperature. The interior fan speed is controlled automatically to achieve optimum heating performance.

G/ Quick Cool

The air-conditioner will change to cooling mode and maximum fan speed for a period of 15 minutes during which the Quick Cool Indicator K will illuminate. After 15 minutes (or if the quick cool button G is pressed again) the air-conditioner will resume operation with the previous settings.

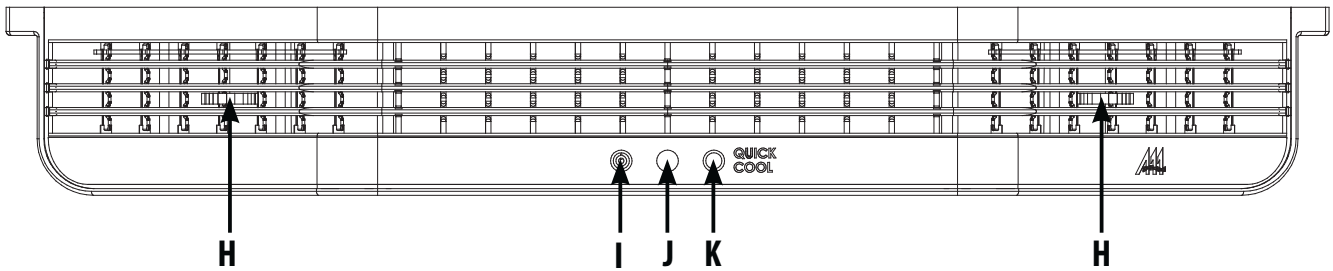

4.2 UNIT

H/ Directional Airflow Controls

Horizontal airflow directional control.

I/ Power Indicator (Blue)

Illuminates when the air-conditioner is switched on.

J/ Infrared Remote Control Receiver

Electronic receiver for remote control signal.

K/ Quick Cool Mode Indicator (White)

Illuminates while the air-conditioner is operating in quick cool mode.

5. OPERATION

Connect the air-conditioner power supply cord to a 10A power outlet.

⚠ CAUTION

Always ensure that the power supply cord is fully uncoiled before operating the unit to prevent overheating. The power cord must be routed so that it cannot be damaged during use or when in transit.

The Power Indicator (I) will illuminate briefly when the power supply is connected and switched on.

- 5.1 Switch the air-conditioner on by pressing the Power button (A) on the remote control while aiming the control in the direction of the air distribution unit Infrared Remote Control Receiver (J). The air-conditioner will beep and the Power Indicator (I) will illuminate to acknowledge the signal.
- 5.2 Set the desired operating mode (Fan, Cooling or Heating), Fan Speed (Low, Med or High) and the desired temperature (16-30°C). The interior fan, exterior fan and compressor will operate automatically depending upon the settings chosen. Fan speed should be selected manually to the lowest level that achieves the desired room temperature.

Once the desired room temperature is reached, the air-conditioner will cycle the compressor and exterior fan to maintain the temperature level.

If the air-conditioner cannot reach a comfortable temperature in cooling mode, increase the fan speed to increase performance.

The desired temperature can be adjusted if you are too hot or cold.

- 5.3 Switch the unit off by pressing the Power button (A) on the remote control. The Power Indicator (I) will extinguish.

Alternatively, the unit can be set to switch off automatically using the Off Timer. While the unit is switched on, press the Timer button (E) on the remote control repeatedly until the display shows the desired number of hours until the air-conditioner will switch off.

NOTE: Whenever the remote control is used, it must be aimed in the direction of the Infrared Remote Receiver (J) on the Air Distribution Unit from a distance of less than 8m. The air distribution unit will beep once and the Power Indicator (I) will flash once to acknowledge the command.

The compressor and exterior fan speed are microprocessor controlled to automatically ensure a long life for your air-conditioner while maintaining the best possible comfort. Depending upon the conditions and air-conditioner settings, you may notice some of the following:

- a. Automatic Compressor Start Protection:** The compressor start may be delayed for up to 3 minutes after selecting cooling or heating mode.
- b. Exterior Fan Speed:** The exterior fan may switch between high and low speeds to minimize the operating noise of the air-conditioner for you and your neighbours.
- c. Cooling Operating Range:** The compressor may not operate in cooling mode if both the indoor and outdoor temperatures exceed approximately 40°C in order to protect the refrigerant system. On very hot days start the air conditioner early to maintain a low indoor temperature. Always keep doors, windows and curtains closed and park in a shaded position to reduce the heat load.
- d. Heating Operating Range:** The air-conditioner is designed to operate in heating mode when the outside temperature is between 0-25°C. If the temperature is outside this range the compressor may not operate in order to protect the refrigerant system.
- e. Preheat:** The interior fan will not switch on in heating mode until the air-conditioner has warmed up sufficiently to deliver comfortably warm air. At very low temperatures this could take up to 10 minutes from the start of the compressor and exterior fan.
- f. De-icing:** The air-conditioner operates as a heat pump when in heating mode. Heat is drawn from the outside air to warm the vehicle. As the outside air temperature drops, less heat is available to the air-conditioner and a decrease in the heating performance may be noticed. When the outside temperature is very low (0-8°C) ice may form on the condenser in the air-conditioner. The microprocessor control has a fully automatic protection function that will remove the ice when required. Depending upon the conditions you may notice the compressor, interior and exterior fans switching off as often as every 15 minutes to protect your air-conditioner and provide maximum comfort.

6. MAINTENANCE

⚠ WARNING

Always disconnect the air-conditioner from the power supply before performing any maintenance.

6.1 INLET AIR FILTER

A dust filter is fitted to the return air inlet of the air-conditioner. This filter is essential to prevent a build up of dust blocking the evaporator. The filter (Part No. TA145520-2000) must be cleaned by vacuuming at least twice per year. Replacement filters are available for purchase as spare parts should the original be damaged.

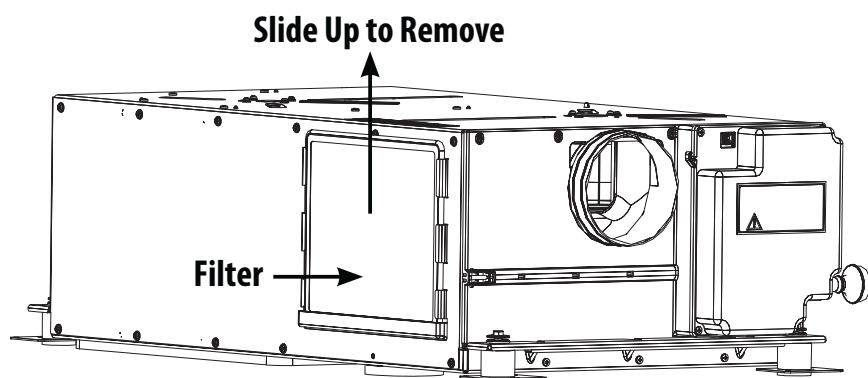

⚠ CAUTION

Failure to clean the filter will result in decreased air-conditioner performance, increased noise and possible overheating and damage to the interior fan. The air-conditioner should never be operated without the filter installed.

6.2 UNDERFLOOR VENTS

A condensate drain and condenser air vents are located under the floor of your vehicle. These vents and drain must be kept clear of blockages that may restrict airflow.

⚠ CAUTION

The vents and drain must be carefully cleaned using a hose or pressure washer after travelling on muddy or icy roads. Failure to clean the vents before operating the air-conditioner may cause poor operating performance, flooding of the interior of the vehicle and damage to the air-conditioner. Avoid damaging the condenser fins, seals & internal components with high pressure water jets.

⚠ CAUTION

If you intend to travel through water that is higher than the floor of your vehicle, all underfloor vents and drains must be sealed to prevent water entry and damage to your air-conditioner. Be sure to unseal all openings before operating the air-conditioner.

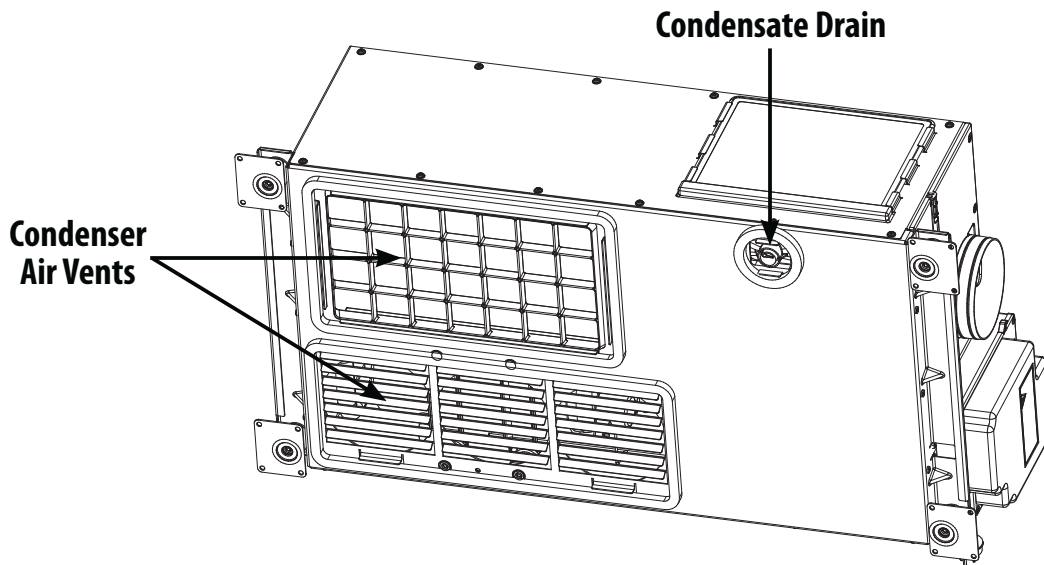
**6.3 REMOTE CONTROL BATTERIES**

The infrared remote control is powered by 2 x AAA (LR03, 24A) 1.5V microbatteries. Depleted batteries in the remote control will cause poor remote operating range. The batteries should be replaced as required with new batteries of the same type by removing the cover from the rear of the remote control. Take care to insert the new batteries with the correct polarity as indicated in the battery compartment.

⚠ CAUTION

Dead batteries may leak and damage the remote if left for long periods. Batteries should be removed from the remote if dead or if the air-conditioner is not to be used for a long period. Damage to the remote control caused by leaking batteries is not included in the terms of the manufacturer's defect warranty.

6.4 GENERAL CONDITION

Regularly inspect the condition of the unit for signs of damage, wear or malfunction.

- Ensure that the unit is securely attached to the floor & the seals are functioning correctly.
- Check that the unit does not touch the sides of the floor cutouts - this may cause noticeable vibration through the floor.
- Visually inspect the supply cord for signs of wear or damage.
- Check that the flexible duct and remote cable are secure free from damage.

If any problems are found, immediately disconnect the unit & contact your nearest service agent for assistance.

7. TECHNICAL DATA

Unit:	UB1 Air-conditioner	Part No. TA448006-6220
Application:	Caravan, camper and pop-top recreational vehicles	
Nominal Cooling Capacity:	2.6 kW (T1)	
Nominal Heating Capacity:	2.0 kW (H)	
Dimensions:	898mm (length) x 458mm (width) x 265mm (height)	
Weight:	45kg	
Power Supply:	230-240V, 50 Hz	
Rated Current:	8 A	
Airflow Volume:	360 m ³ /h	
Refrigerant:	R407c	
Refrigerant Amount:	750 g	
Maximum operating incline:	8°	
Operating Temperature Range:	Cooling (16-45°C)	Heating (0-25°C)

7.1 WIRING DIAGRAM

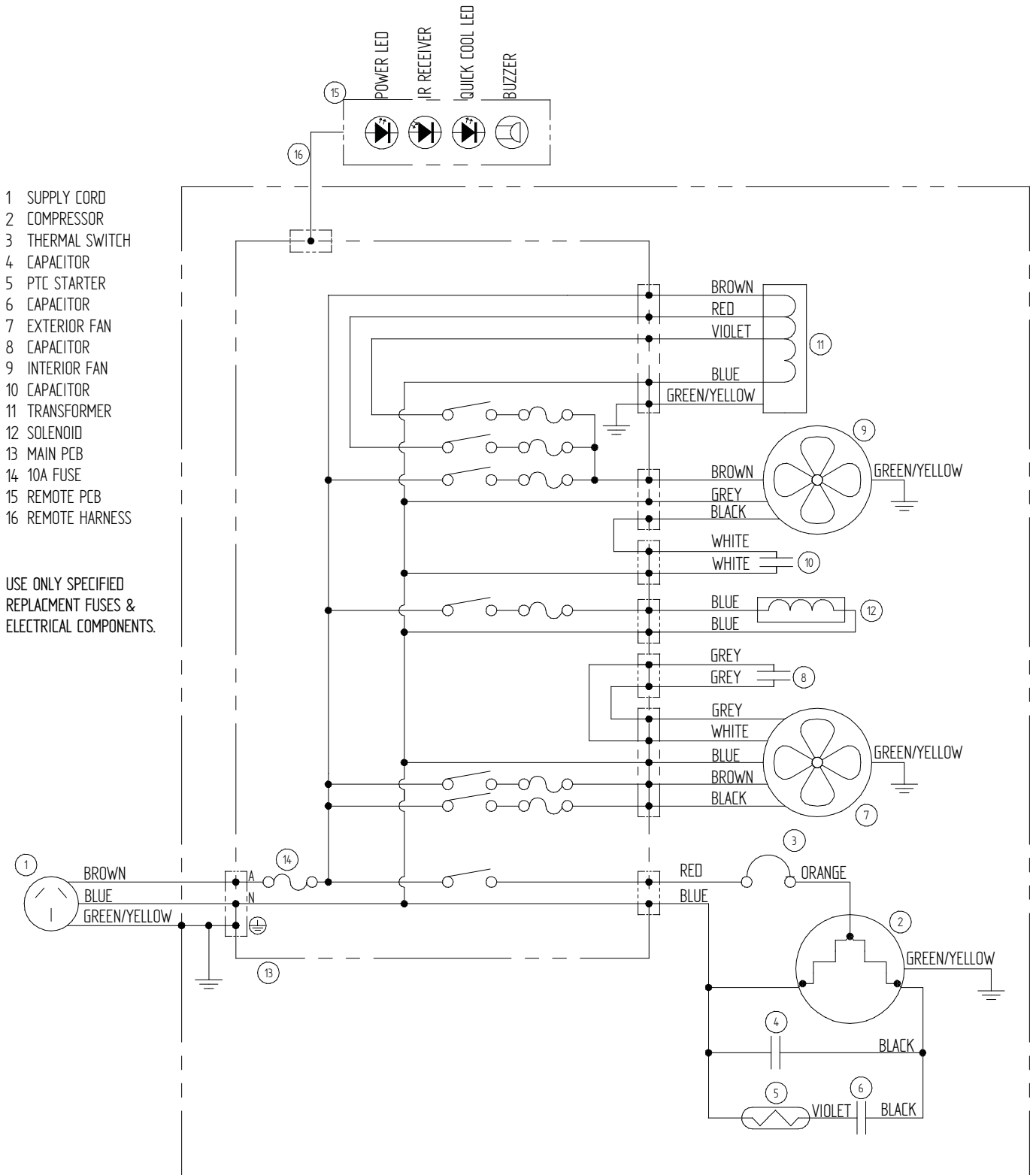

8. TROUBLESHOOTING

Symptom	Cause	Remedy
Unit does not operate	Power supply is OFF	Check supply cord, outlet & supply circuit breaker. When the supply is connected, the POWER & QUICK COOL LED's should flash once to indicate that the supply has been switched on.
	Control cable is disconnected	Check that the control cable is securely connected to the main unit.
	Power interruption	To protect itself from damage, the unit may switch off (return to standby) if power is momentarily interrupted. Ensure that the unit is connected to a clean power supply before restarting.
	Remote control not working	Remote control instructions are confirmed by a beep & the power LED blinking once. There is a short delay between a command being sent & the unit responding. Ensure that remote control is being pointed towards the air distribution unit from a distance less than 8m. Replace the batteries if necessary.
Exterior fan changes speed.	The speed of the exterior fan changes or switches off occasionally.	The exterior fan speed is adjusted based on system & ambient conditions. Where possible, the exterior fan will switch to low speed for less disturbance to you & your neighbours.
Poor performance	Blocked condenser.	Check that the condenser (under the floor) is not blocked with dust, mud or rubbish. Clean if necessary.
	Blocked filter.	Inspect the indoor air filter on the side of the main unit. Clean or replace if necessary.
	Air duct disconnected or damaged	Reconnect duct or contact service centre for replacement.
	Outside of operating temperature range.	Use within operating temperature range.

Compressor cuts or does not start.	There system has a number of inbuilt protection mechanisms to protect the compressor from operating outside its design limits.	Ensure that the unit is being used within its operating temperature range. Refer to section 3 for a description of some of the operating modes you may experience.
Unit operating continuously	System unable to reach desired setpoint.	Change temperature on remote control (confirmed by beep & LED blink. Close all doors, windows & curtains to improve insulation & reduce the load on the system.
No fan speed control in heating mode	In heating mode, the fan speed is automatically controlled by the inbuilt microprocessor.	The fan speed is adjusted based on system & ambient conditions to provide the most comfortable indoor environment.
Both LED's flashing. Unit does not operate.	Both LED's flash together.	Power supply voltage is out of acceptable range for safe operation of the unit. Ensure that unit is connected to supply of correct voltage.
	Both LED's flash alternately	Internal fault detected. Contact service centre for assistance.
Condensate formation	Condensate may form on cold surfaces when operating in humid conditions.	Keep all cupboards/covers closed if the air duct passes through them to prevent the formation of condensate.
	The evaporator condensate drain is blocked. This may be indicated by water droplets being carried in the air or by flooding around the base of the unit.	Ensure that the condensate drain is clear of dirt or other foreign materials.

If symptoms persist after the above actions have been taken, disconnect the power and contact your nearest service dealer or a qualified technician.

9. WARRANTY DETAILS

This unit provides a 12 month manufacturer's defect warranty on the UB1 air-conditioner. This warranty covers the cost of labour and parts to repair malfunctions due to material or production defects.

The 12 month warranty period extends from the date of first retail purchase and may not be transferred or assigned to any subsequent purchaser. This warranty applies where the caravan is used solely within Australia.

If warranty service is required, the purchaser or service agent must contact DENSO for service approval prior to repair. Contact can be made as below during normal business hours (9am - 5pm EST) Monday to Friday.

Phone: (03) 8761 1449

Fax: (03) 8761 1501

Email: service.department@denso.com.au

Exclusions:

The manufacturer's defect warranty does not cover the following items:

1. The cost of removal of the unit from its installation (including, but not limited to, the cost of disassembling furniture or other actions that may be required due to the nature of the installation)
2. Packaging and delivery costs related to any return of defective parts to the nearest authorized service agent.
3. The cost of replacement of the air inlet filter or batteries which are considered consumable items.
4. The repair of damage cause by use of the air-conditioner outside the operating instructions.
5. Damage to any part of the air-conditioner, air distribution unit or remote control caused by normal wear and tear.
6. Damage resulting from failure to conduct routine maintenance as outlined in the operating manual.
7. Deliberate misuse, unauthorised alteration, modification or substitution of parts.
8. Indirect or consequential damage caused by the operation of the air-conditioner.
9. Damage to the air-conditioner caused by transport or mishandling.
10. Travel expenses of a service agent travelling to the repair location should this be required.
11. Service costs in the case that a unit is found to be free of manufacturer's defects.

The terms of this warranty are in addition to those conferred under law in the state or territory of purchase.

The unit serial number can be found in this position on the front of the unit.

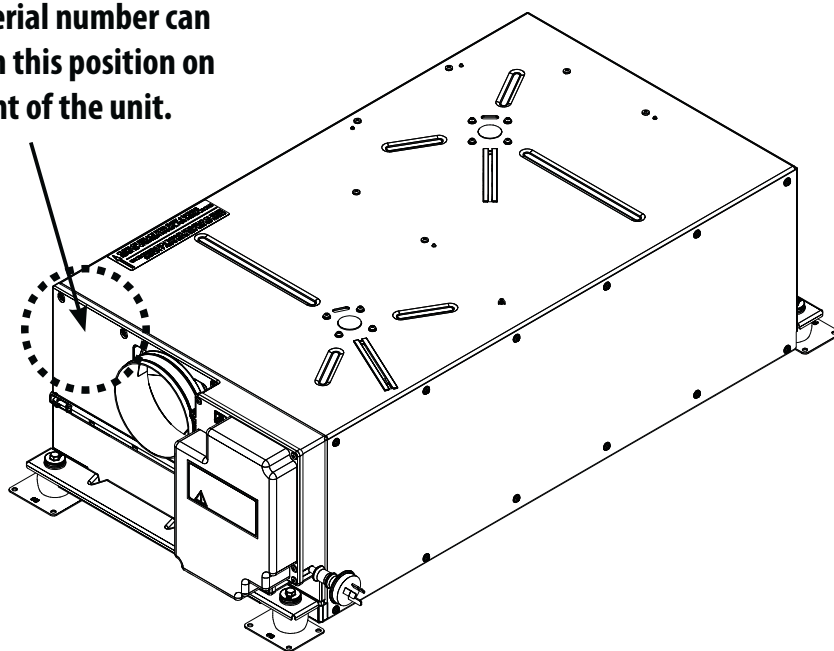

PLEASE REMOVE AND RETURN WARRANTY REGISTRATION CARD WITHIN 30 DAYS OF PURCHASE

Published: June 2012

Revised:

Editing/Issuing Department:

DENSO Automotive Systems Australia
Service Department

2-46 Merrindale Drive, Croydon VIC Australia 3136

AFFIX
POSTAGE
STAMP

DENSO AUTOMOTIVE SYSTEMS AUSTRALIA

Attn: Service Department

2-46 Merrindale Drive

Croydon VICTORIA 3136

UB1 WARRANTY REGISTRATION CARD

NAME: _____

ADDRESS: _____

_____ P/CODE: _____

PHONE No: _____

BRAND OF CARAVAN: _____

MODEL: _____

DATE OF PURCHASE: _____

PURCHASED FROM: _____

INSTALLED BY: _____

SERIAL No: _____